



High Quality Turning Centers



HT-40/60/80/100 A,B,C,D,E Multiaxial Series
HT-30 Multiaxial Series

High Quality Turning Centers



◉ Twin Spindles / Twin Turrets

The JOHN FORD HT Series High Quality Turning Centers are designed to meet all the requirements of what you need not only today, but also in the future.

The HT Series starts with a time proven slant bed design and offers many of the same space-saving characteristics.



HT-30A-2SD / HT-40A-2SD / HT-4

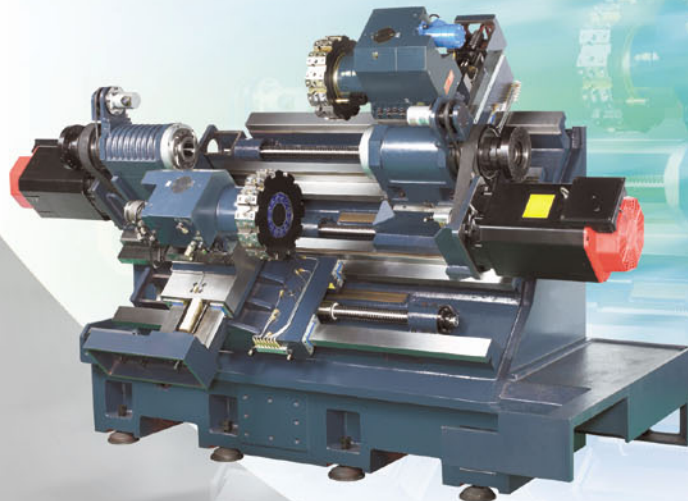



are designed out of the ordinary to meet
for rigidity, chip flow, accessibility, and

Reliable Design

IDEAS advanced engineering software is utilized to optimize the design of the HT Series. It is used to calculate the physical and material properties of the components used, ensuring no weakness in the machine.

ANSYS Finite Element Analysis (FEA) software is employed to analyze all components of the HT series to determine the optimal machine structure.

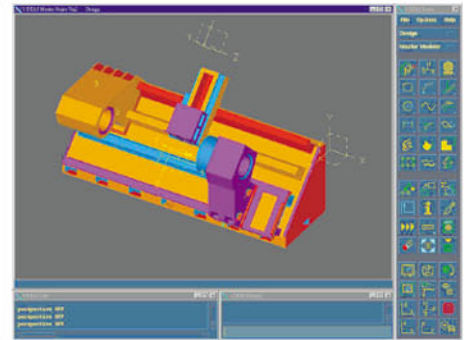
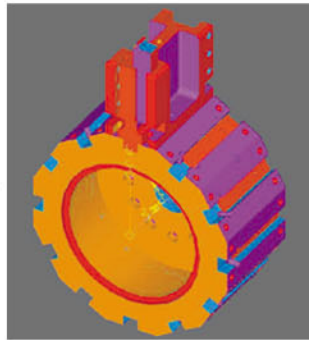

A New Machine for the New Millennium

Twin Turrets with Tailstock

These machines are built for outstanding performance in medium and large lot production runs.

These machines always deliver the precision and efficiency which are far beyond the ordinary.

40A-2D

Advanced Engineering and Solid Construction

- Meehanite cast iron
- Torque tube bed
- Rigid box ways
- Large diameter pretensioned ballscrews
- Direct coupled ballscrews

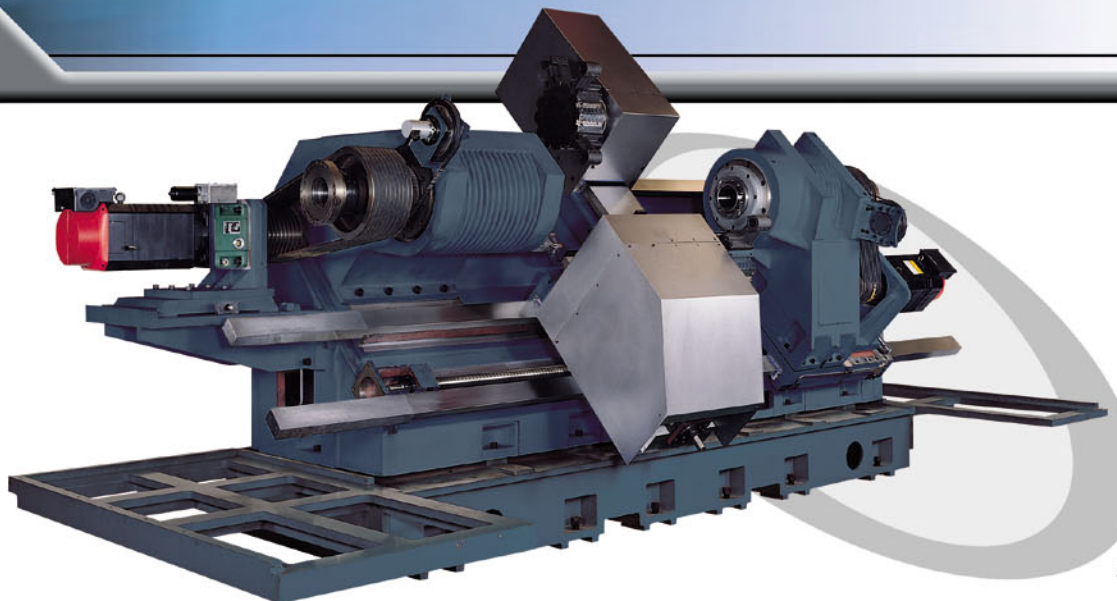

Multiple Construction to Meet Your Need

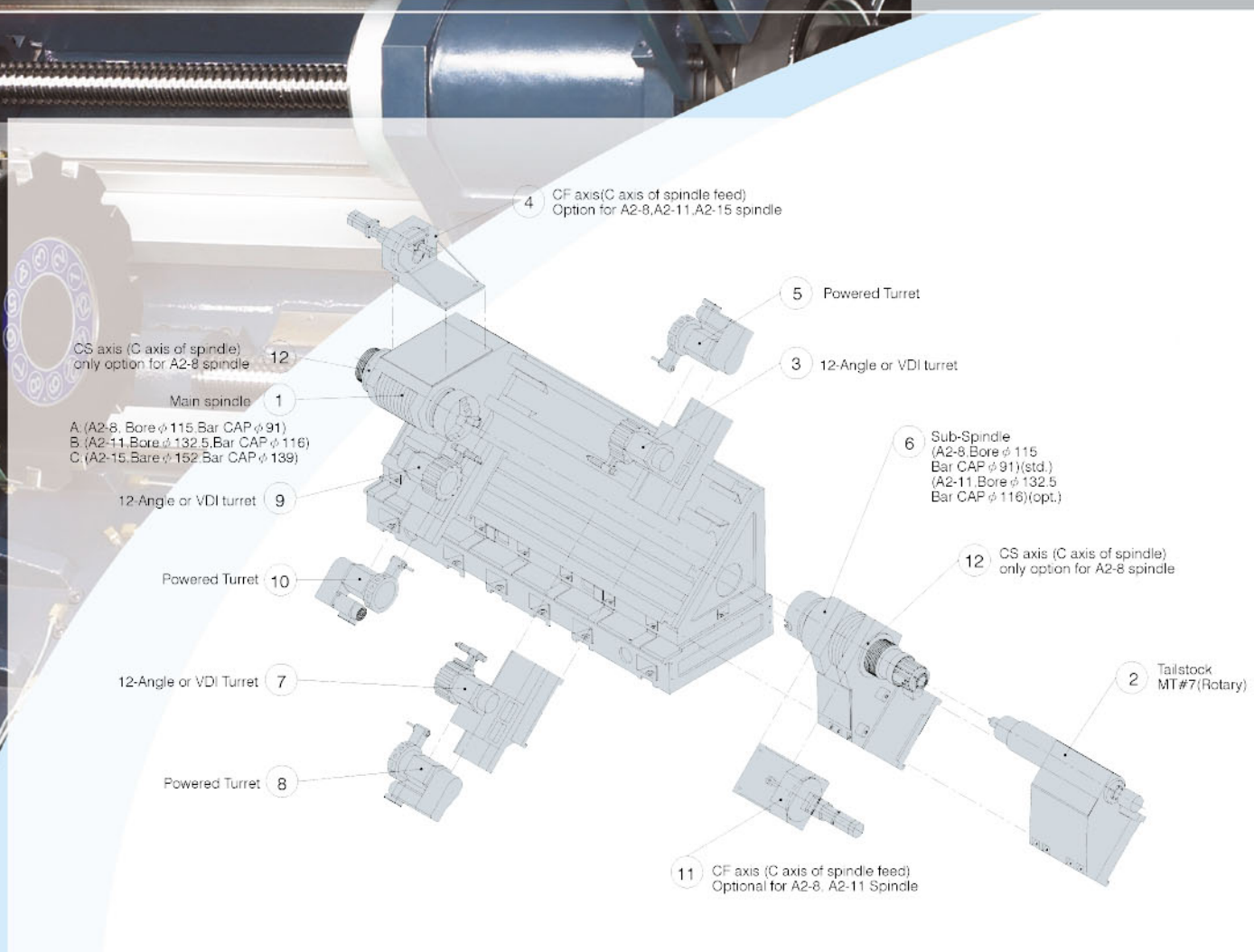

CS axis (C axis of spindle)
only option for A2-8 spindle

Main spindle 1
A. (A2-8, Bore φ 115, Bar CAP φ 91)
B. (A2-11, Bore φ 132.5, Bar CAP φ 116)
C. (A2-15, Bore φ 152, Bar CAP φ 139)

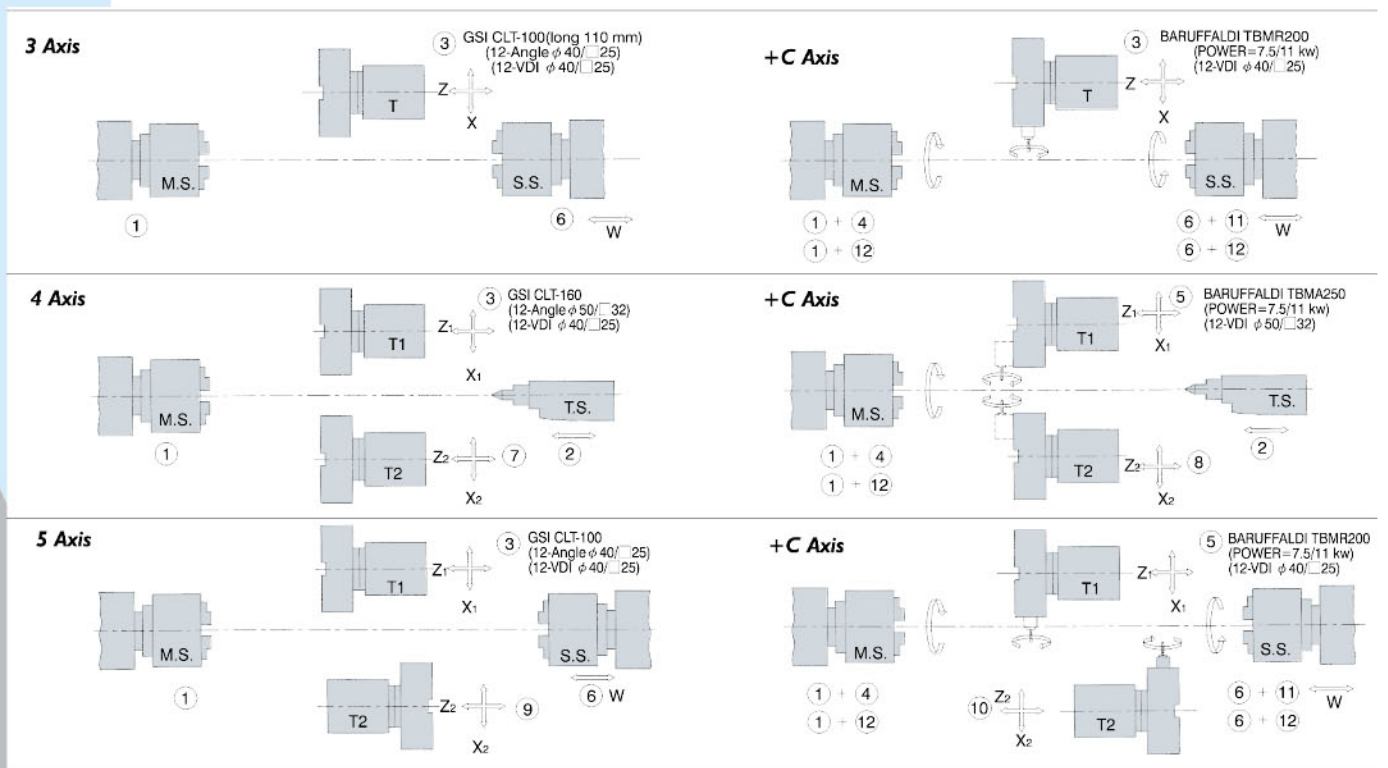

High Performance Spindles

High Performance Belt-type Spindles



Spindle

The spindle is mounted on precision-double-row roller bearings in conjunction with angular contact ball bearings, providing highest rigidity and accuracy.

The spindle is manufactured from alloy steel, heat treated and precision ground for maximum uniformity and durability.

The quill inner and outer lining is precision ground for fit with the spindle, thus ensuring extreme concentricity and accuracy of turned parts, and spindle service life is greatly extended.

Dimensions of Head

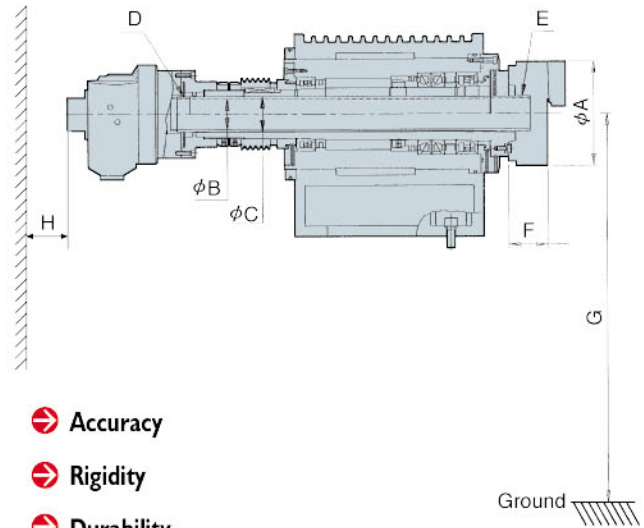

- ➔ Accuracy
- ➔ Rigidity
- ➔ Durability
- ➔ Efficiency

Unit: mm

Model	Dimension	A	B	C	D	E	F	G	H
HT-30/35 Series	Std.	φ 210 (8")	φ 51	φ 65	M60 x P2.0	M60 x P2.0	103	1210	345
HT-40/60/80/100, A	Std.	φ 315 (12")	φ 91	φ 115	M100 x P2.0	M100 x P2.0	122	1595	380
	Opt.	φ 381 (15")					160		345
HT-40/60/80/100, B	Std.	φ 381 (15")	φ 116	φ 132.5	M130 x P2.0	M130 x P2.0	149	1595	345
	Opt.	φ 450 (18")					149		345
HT-40/60/80/100, C	Std.	φ 510 (20")	φ 139	φ 152	M175 x P3.0	M150 x P2.0	144	1605	270
	Opt.	φ 610 (24")					180		270
HT-40/60/80/100, D	Std.	φ 508 (20")	φ 165	φ 185	M175 x P3.0	M175 x P3.0	155	1605	270
	Opt.	φ 610 (24")					183		270
HT-40/60/80/100, E	Std.	φ 610 (24")	φ 204	φ 236	M215 x P3.0	M215 x P3.0	183	1605	310

Dimensions

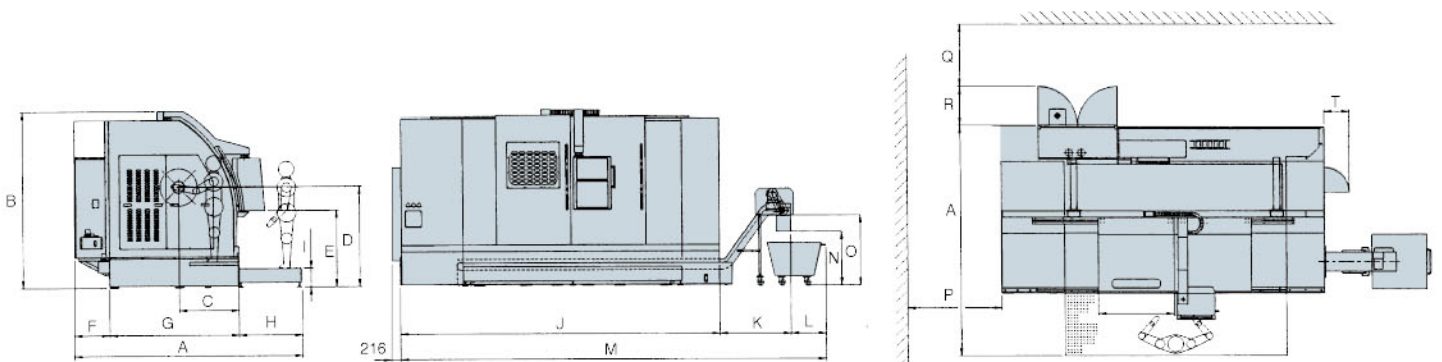

Unit: mm

Model	Item	A	B	C	D	E	F	G	H	I	J	K	L	M	N	O	P	Q	R	T
HT-30 Series		2250	2085	615	1210	1050	540	1350	-	-	3175	815	545	4535	975	1085	1000	1000	550	-
HT-35 Series		2250	2310	640	1275	1182	560	1420	-	-	3850	1080	660	5395	780	1030	1000	1000	550	-
HT-40 A/B/C/D/E		3615	2870	965	1595	1220	460	2130	1025	300	5140	1145	560	6845	850	1110	1500	1000	660	730
HT-60 A/B/C/D/E		3615	2870	965	1595	1220	460	2130	1025	300	5640	1145	560	7345	850	1110	1500	1000	660	730
HT-80 A/B/C/D/E		3615	2870	965	1595	1220	460	2130	1025	300	6140	1145	560	7845	850	1110	1500	1000	660	730
HT-100 A/B/C/D/E		3615	2940	983	1605	1255	460	2130	1025	300	6600	1250	560	8410	850	1110	1500	1000	660	730

Spindle Power & Torque Chart

HT-30/35 Series FANUC AC α P30

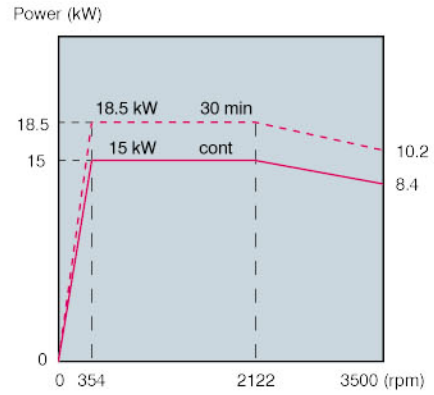
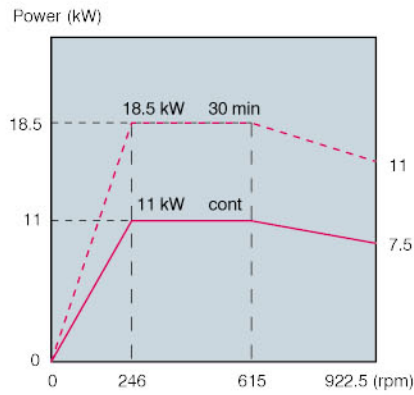
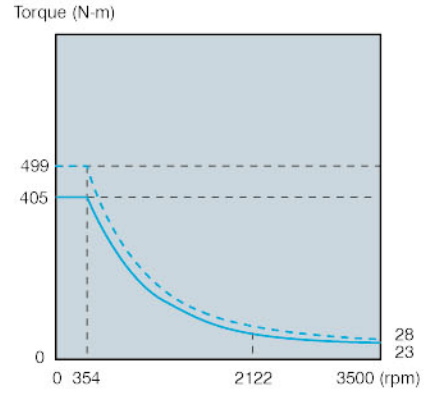
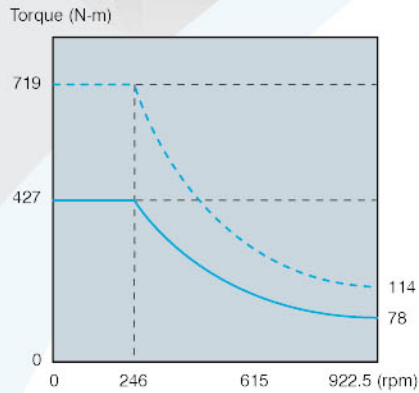

HT-A Series with ZF gear box

Low speed, ratio=0.109

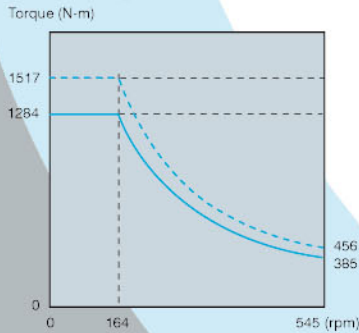

High speed, ratio=0.6

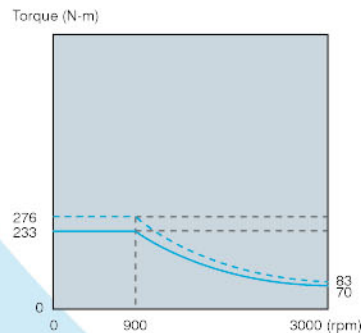

Low speed, ratio=0.109

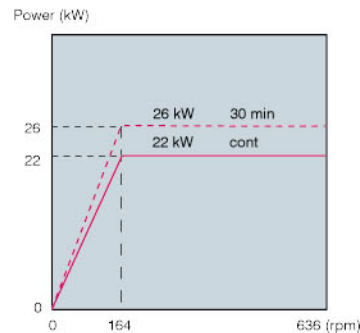

High speed, ratio=0.6

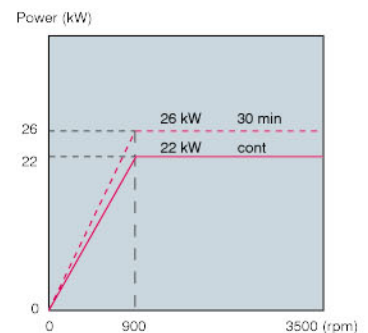

HT-B Series with Auto 4-speed gear box

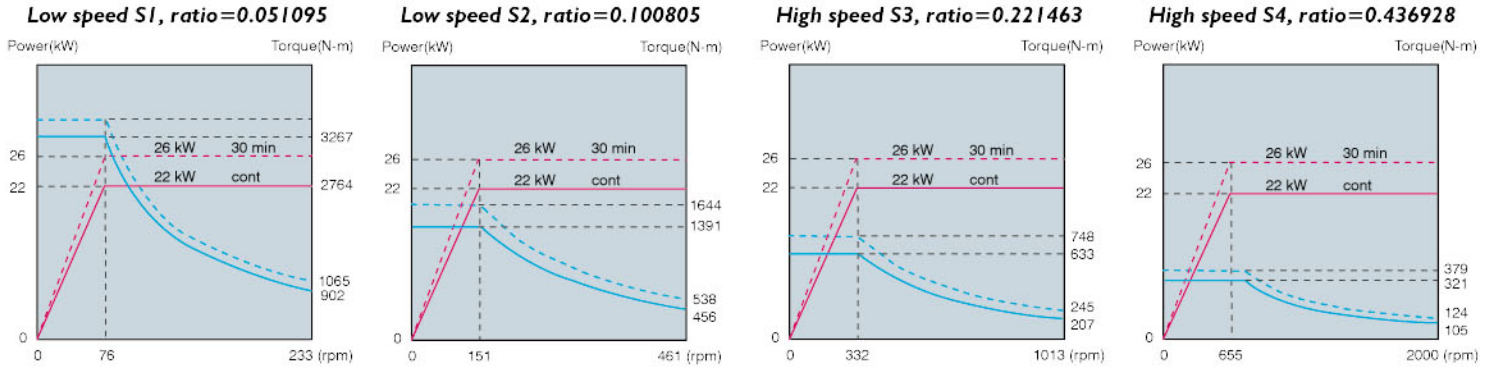

HT-C Series with Auto 4-speed gear box

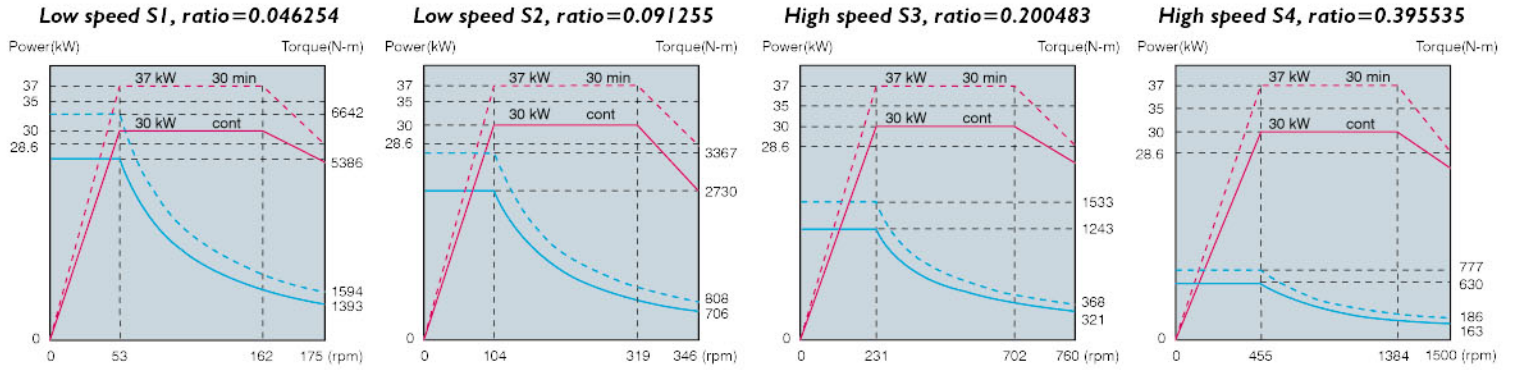

Construction

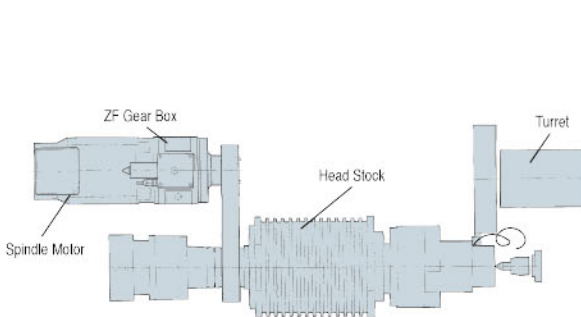

With ZF gear box drive

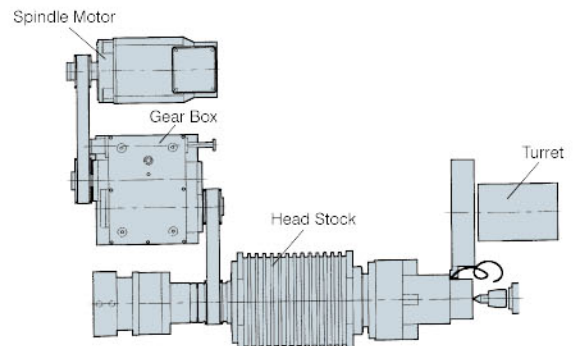

With Auto 4-speed drive

Powered Turret + C-Axis Function



C-axis provides flexible turning performance for handling cam or special profiled parts that need milling / drilling / tapping operations. 0.001 degree indexing allows accurate circular positioning.

Item	Power Turret Model		
	TBMR 200	TBMA 250	
Max. speed of turret	3800 rpm	3276 rpm	
Twist drilling	$d \times a$ (mm)x(mm/°)		20×0.20
Slot milling	$d \times P \times a$ (mm)x(mm)x(mm/min)		$25 \times 14 \times 40$
Tapping	$d \times p$ (mm)x(mm)		$M16 \times 2$
Toolholder shaft size	VDI 40	VDI 50	
Motor horsepower	AC 3.7 / 5.5 kW	AC 3.7 / 5.5 kW	

Live Tooling

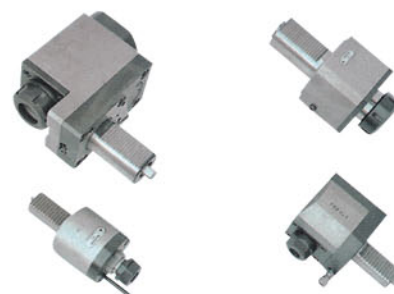

Examples for Machining with Live Tools

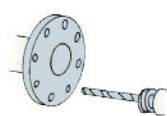

Drilling

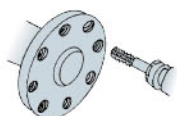

Thread cutting

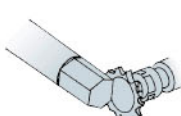

Face cutting

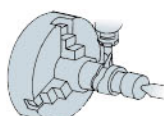

Cam cutting

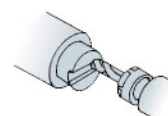

Slot cutting

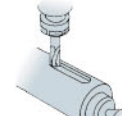

Key way cutting

Tool System

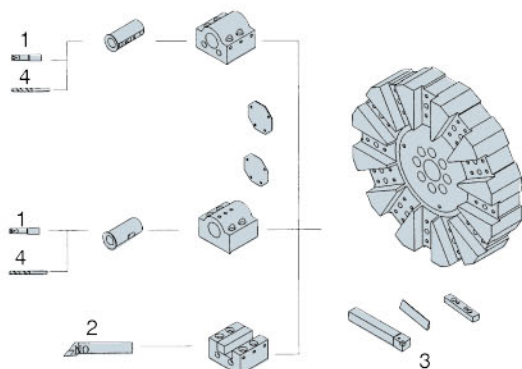

4 Axis Series

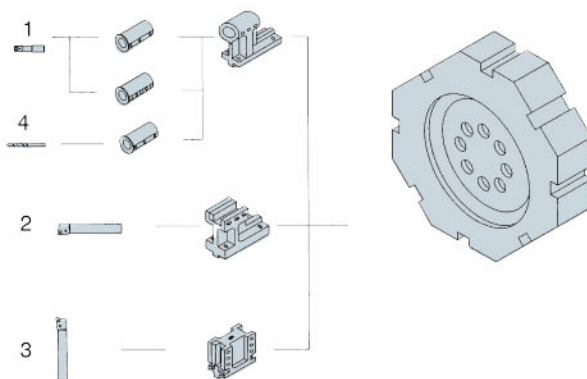

3/5 Axis Series

No.	Model Tool Type	HT-30 / 35 / 40 / 60 / 80 / 100 (4 Axis)	
		Metric System (mm)	Imperial System
1	Bore	$\phi 12, \phi 16, \phi 20, \phi 25$ $\phi 32, \phi 32, \phi 40, \phi 50$	$\phi 1/2", \phi 5/8", \phi 3/4", \phi 1"$ $\phi 1-1/4", \phi 1-1/2", \phi 2"$
2	End	<input type="checkbox"/> 32	<input type="checkbox"/> 1-1/4"
3	Outerdia	<input type="checkbox"/> 32	<input type="checkbox"/> 1-1/4"
4	Drill	MT#2, #3, #4, #5	

No.	Model Tool Type	HT-30 / 35 / 40 / 60 / 80 / 100 (3/5 Axis)	
		Metric System (mm)	Imperial System
1	Bore	$\phi 8, \phi 10, \phi 12, \phi 16$ $\phi 20, \phi 25, \phi 32, \phi 40$	$\phi 1/4", \phi 1/2", \phi 5/8", \phi 3/4"$ $\phi 1", \phi 1-1/4", \phi 1-1/2"$
2	End	<input type="checkbox"/> 25	<input type="checkbox"/> 1"
3	Outerdia	<input type="checkbox"/> 25	<input type="checkbox"/> 1"
4	Drill	MT#2, #3, #4	

3-Axis Series Specifications

Item		Model	HT-30-2S	HT-35-2S	HT-40-2S	HT-60-2S	HT-80-2S	HT-100-2S	
Swing over bed (mm)			φ 580 (22.8")		φ 750 (29.5")	φ 730 (28.7")	φ 710 (28")	φ 690 (27.2")	
Swing over cross slide (mm)			φ 300 (11.8")	φ 330 (13")	φ 600 (23.6")				
Distance between Centers (mm)			550 (21.7")	800 (31.5")	1000 (39.4")	1500 (59")	2000 (78.7")	2500 (98.4")	
Main	Chuck size (in)	Std.	8" (φ 203.2 mm)	10" (φ 254 mm)	A: 12" (φ 315 mm) / B: 15" (φ 381 mm) / C, D: 20" (φ 510 mm) / E: 24" (φ 610 mm)				
		Opt.			A: 15" (φ 381 mm) / B: 18" (φ 450 mm) / C, D: 24" (φ 610 mm) / E: —				
	Bar capacity (mm)	Std.	φ 51 (2")	φ 76.5 (3")	A: φ 91 (3.6") / B: φ 116 (4.6") / C: φ 139 (5.5") / D: φ 165 (6.5") / E: φ 204 (8")				
		Opt.	A: φ 95 (3.7")						
	Spindle nose			A2-6	A2-8	A: A2-8 / B: A2-11 / C: A2-12 / D, E: A2-15			
	Spindle bore (mm)			φ 65 (2.6")	φ 86 (3.4")	A: φ 115 (4.5") / B: φ 132.5 (5.2") / C: φ 152 (6") / D: φ 185 (7.3"), Geared head φ 176 (6.9") / E: φ 236 (9.3")			
	Spindle	Spindle speed step	Std.	One step		A, B: Auto Hi-Lo / C, D, E: Auto 4-Steps			
			Opt.			B: Auto 4-Steps			
		Spindle speed range (rpm)	Std.	4500	3500	A: 3000 for 12" chuck, 2000 for 15" chuck / B: 2000 for Hi-Lo / C: 1200 / D: 1000 / E: 750			
			Opt.			B: 2000 for Auto 4-Steps			
Spindle motor (kW)	Std.	11 / 15	15 / 18.5	A, B: 22 / 26 / C, D, E: 30 / 37					
	Opt.			B: 30 / 37 / C, D, E: 37 / 45					
Spindle bearing diameter (mm)			φ 100 (3.9")	φ 130 (5.1")	A: φ 160 (6.3") / B: φ 180 (7") / C: φ 200 (7.9") / D: φ 240 (9.4") / E: φ 280 (11")				
Sub	Chuck size (in)	Std.	8" (φ 203.2 mm)		A: 12" (φ 315 mm) / B, C, D, E: 15" (φ 381 mm)				
		Opt.			A: 15" (φ 381 mm)				
	Bar capacity (mm)			φ 51 (2")	φ 91 (3.6") (Std.) / φ 95 (3.7") (Opt.) / φ 116 (4.6") (Opt. for A2-11)				
	Spindle nose			A2-6	A2-8 (Std.) / A2-11 (Opt.)				
	Spindle bore (mm)			φ 65 (2.6")	φ 115 (4.5") (Std.) / φ 132.5 (5.2") (Opt.)				
	Spindle speed step			One step	A: One step / B, C, D, E: Auto Hi-Lo				
	Spindle speed range (rpm)			4500	A: 3000 for 12" chuck, 2000 for 15" chuck / B: 2000 / C: 1500 / D: 1000 / E: 750				
	Spindle motor (kW)			11 / 15 (Std.)	A: 9 / 11 ; B: 11 / 15 ; C, D, E: 15 / 18.5				
Spindle bearing diameter (mm)			φ 100 (3.9")	φ 160 (6.3") (Std.) / φ 180 (7.1") (Opt.)					
No. of tools			12						
Cross travel (X-axis) (mm)			160 (6.3")	175 (6.9")	320 (12.6")				
Longitudinal travel (Z ₁ /Z ₂ -axis) (mm)			550 (21.7")	760 (30")	1000 (39.4")	1500 (59")	2000 (78.7")	2500 (98.4")	
Rapid traverse (m/min)			X: 15, Z / W: 18		X: 12, Z: 15, W: 10				
Servo motor (X-axis) (kW)			4						
Servo motor (Z ₁ /Z ₂ -axis) (kW)			4				7		
Servo motor (W-axis) (kW)			4				7		
Bed inclination			45°						
Weight (kg)			7500 (16500 lb)	11000 (24200 lb)	A: 16500 (36300 lb) B: 16550 (36410 lb) C: 16600 (36520 lb) D: 16650 (36630 lb) E: 16700 (36740 lb)	A: 18500 (40700 lb) B: 18550 (40810 lb) C: 18600 (40920 lb) D: 18650 (41030 lb) E: 18700 (41140 lb)	A: 20500 (45100 lb) B: 20550 (45210 lb) C: 20600 (45320 lb) D: 20650 (45430 lb) E: 20700 (45540 lb)	A: 22500 (49500 lb) B: 22550 (49610 lb) C: 22600 (49720 lb) D: 22650 (49830 lb) E: 22700 (49940 lb)	
Machine dimensions (mm)	W x H		2300 x 2300 (90.6" x 90.6")		3470 x 2840 (136.6" x 111.8")			3595 x 2940 (141.5" x 115.7")	
	L		5100 (200.8")	5600 (220.5")	5200 (204.7")	5600 (220.5")	6000 (236.2")	6600 (259.8")	

- All data subject to change without notice.
- All the specifications are listed with the FANUC CNC system.

4-Axis Series Specifications

Item		Model	HT-30-2D	HT-35-2D	HT-40-2D	HT-60-2D	HT-80-2D	HT-100-2D
Swing over bed (mm)			φ 580 (22.8")		φ 750 (29.5")	φ 730 (28.7")	φ 710 (28")	φ 690 (27.2")
Swing over cross slide (mm)			φ 330 (13")		φ 600 (23.6")			
Distance between Centers (mm)			550 (21.7")	800 (31.5")	1000 (39.4")	1500 (59")	2000 (78.7")	2500 (98.4")
Chuck size (in)	Std.		10" (φ 254 mm)		A: 12" (φ 315 mm) / B: 15" (φ 381 mm) / C, D: 20" (φ 510 mm) / E: 24" (φ 610 mm)			
	Opt.				A: 15" (φ 381 mm) / B: 18" (φ 450 mm) / C, D: 24" (φ 610 mm) / E: —			
Bar capacity (mm)	Std.		φ 76.5 (3")		A: φ 91 (3.6") / B: φ 116 (4.6") / C: φ 139 (5.5") / D: φ 165 (6.5") / E: φ 204 (8")			
	Opt.				A: φ 95 (3.7")			
Spindle nose			A2-8		A: A2-8 / B: A2-11 / C, D, E: A2-15			
Spindle bore (mm)			φ 86 (3.4")		A: φ 115 (4.5") / B: φ 132.5 (5.2") / C: φ 152 (6") / D: φ 185 (7.3") / Geared head φ 176 (6.9") / E: φ 236 (9.3")			
Spindle speed step	Std.		One step		A, B: Auto Hi-Lo / C, D, E: Auto 4-Steps			
	Opt.				B: Auto 4-Steps			
Spindle speed range (rpm)	Std.		3500		A: 3000 for 12" chuck, 2000 for 15" chuck / B: 2000 for Hi-Lo / C: 1200 / D: 1000 / E: 750			
	Opt.				B: 2000 for Auto 4-Steps			
Spindle motor (kW)	Std.		15 / 18.5		A, B: 22 / 26 ; C, D, E: 30 / 37			
	Opt.				B: 30 / 37 ; C, D, E: 37 / 45			
Spindle bearing diameter (mm)			φ 130 (5")		A: φ 160 (6.3") / B: φ 180 (7") / C: φ 200 (7.9") / D: φ 240 (9.4") / E: φ 280 (11")			
No. of tools (T ₁ / T ₂)			12 / 12					
Cross travel (X ₁ / X ₂ -axis) (mm)			175 / 175 (6.9")		320 / 320 (12.6")			
Longitudinal travel (Z ₁ / Z ₂ -axis) (mm)			550 (21.7")	760 (30")	1000(39.4")/760(29.9")	1500(59")/1260(49.6")	2000(78.7")/1760(69.3")	2500(98.4")/2260(89")
Rapid traverse (m/min)			X: 15, Z: 18		X: 12, Z: 15			
Tailstock travel (mm)			530 (20.9")	740 (29.1")	700 (27.6")	1200 (47.2")	1700 (66.9")	2200 (86.6")
Tailstock quill travel (mm)			100 (3.9")		200 (7.9")			
Tailstock quill diameter (mm)			φ 85 (3.3")		φ 200 (7.9")			
Tailstock Spindle taper	Rotary		MT#5		MT#7			
Servo motor (X ₁ / X ₂ -axis) (kW)			3		4			
Servo motor (Z ₁ / Z ₂ -axis) (kW)			4				7	
Bed inclination			45°					
Weight (kg)			7200 (15840 lb)	11000 (24200 lb)	A: 17000 (37400 lb) B: 17050 (37510 lb) C: 17100 (37620 lb) D: 17150 (37730 lb) E: 17200 (37840 lb)	A: 19000 (41800 lb) B: 19050 (41910 lb) C: 19100 (42020 lb) D: 19150 (42130 lb) E: 19200 (42240 lb)	A: 21000 (46200 lb) B: 21050 (46310 lb) C: 21100 (46420 lb) D: 21150 (46530 lb) E: 21200 (46640 lb)	A: 23000 (50600 lb) B: 23050 (50710 lb) C: 23100 (50820 lb) D: 23150 (50930 lb) E: 23200 (51040 lb)
Machine dimensions (mm)	W x H		2300 x 2300 (90.6" x 90.6")		3470 x 2840 (136.6"x111.8")			3595 x 2940 (141.5"x115.7")
	L		5100 (200.8")	5600 (220.5")	5200 (204.7")	5600 (220.5")	6000 (236.2")	6600 (259.8")

■ All data subject to change without notice.

■ All the specifications are listed with the FANUC CNC system.

Standard Accessories:

- Coolant system
- Splash guard
- Through hole 3-jaw chuck
- Programmable hydraulic tailstock
- Chain type chip conveyor
- Tool box and various manuals
- Tool holders (direct mounting type)
- Auto lubrication with alarm
- Halogen working lamp
- Rotary tailstock (4 Axis series)
- Fanuc 0iTD-2 path controller (only for 2D and 2SD series)

5-Axis Series Specifications

Item		Model	HT-30-2SD	HT-35-2SD	HT-40-2SD	HT-60-2SD	HT-80-2SD	HT-100-2SD
Swing over bed (mm)			φ 580 (22.8")		φ 750 (29.5")	φ 730 (28.7")	φ 710 (28")	φ 690 (27.2")
Swing over cross slide (mm)			φ 330 (13")		φ 600 (23.6")			
Distance between Centers (mm)			550 (21.7")	800 (31.5")	1000 (39.4")	1500 (59")	2000 (78.7")	2500 (98.4")
Main Spindle	Chuck size (in)	Std.	8" (φ 203.2 mm)	10" (φ 254 mm)	A: 12" (φ 315 mm) / B: 15" (φ 381 mm) / C, D: 20" (φ 510 mm) / E: 24" (φ 610 mm)			
		Opt.			A: 15" (φ 381 mm) / B: 18" (φ 450 mm) / C, D: 24" (φ 610 mm) / E: —			
	Bar capacity (mm)	Std.	φ 51 (2")	φ 76.5 (3")	A: φ 91 (3.6") / B: φ 116 (4.6") / C: φ 139 (5.5") / D: φ 165 (6.5") / E: φ 204 (8")			
		Opt.			A: φ 95 (3.7")			
	Spindle nose		A2-6	A2-8	A: A2-8 / B: A2-11 / C, D, E: A2-15			
	Spindle bore (mm)		φ 65 (2.6")	φ 86 (3.4")	A: φ 115 (4.5") / B: φ 132.5 (5.2") / C: φ 152 (6") / D: φ 185 (7.3"), Geared head φ 176 (6.9") / E: φ 236 (9.3")			
	Spindle speed step	Std.	One step		A, B: Auto Hi-Lo / C, D, E: Auto 4-Steps			
		Opt.			B: Auto 4-Steps			
	Spindle speed range (rpm)	Std.	4500	3500	A: 3000 for 12" chuck, 2000 for 15" chuck / B: 2000 for Hi-Lo / C: 1200 / D: 1000 / E: 750			
		Opt.			B: 2000 for Auto 4-Steps			
Spindle motor(kW)	Std.	11 / 15	15 / 18.5	A: 22 / 26 ; B: 22 / 26 ; C, D, E: 30 / 37				
	Opt.			B: 30 / 37 ; C, D, E: 37 / 45				
Spindle bearing diameter (mm)		φ 100 (3.9")	φ 130 (5.1")	A: φ 160 (6.3") / B: φ 180 (7") / C: φ 200 (7.9") / D: φ 240 (9.4") / E: φ 280 (11")				
Sub Spindle	Chuck size (in)	Std.	8" (φ 203.2 mm)		A: 12" (φ 315 mm) / B, C, D, E: 15" (φ 381 mm)			
		Opt.			A: 15" (φ 381 mm)			
	Bar capacity (mm)		φ 51 (2")	φ 91 (3.6") (Std.) / φ 95 (3.7") (Opt.) / φ 116 (4.6") (Opt. for A2-11)				
	Spindle nose		A2-6	A2-8 (Std.) / A2-11 (Opt.)				
	Spindle bore (mm)		φ 65 (2.6")	φ 115 (4.5") (Std.) / φ 132.5 (5.2") (Opt.)				
	Spindle speed step		One step	A: One step / B, C, D, E: Auto Hi-Lo				
	Spindle speed range (rpm)		4500	A: 3000 for 12" chuck, 2000 for 15" chuck / B: 2000 / C: 1500 / D: 1000 / E: 750				
	Spindle motor (kW)		11 / 15 (Std.)	A: 9 / 11 ; B: 11 / 15 ; C, D, E: 15 / 18.5				
Spindle bearing diameter (mm)		φ 100 (3.9")	φ 160 (6.3") (Std.) / φ 180 (7.1") (Opt.)					
No. of tools (T ₁ / T ₂)		12 / 12						
Cross travel (X ₁ / X ₂ -axis) (mm)		175 / 175 (6.9")			320 / 320 (12.6")			
Longitudinal travel (Z ₁ / Z ₂ -axis)(mm)		460 (18.1")	760 (30")	1000 (39.4")	1500 (59")	2000 (78.7")	2500 (98.4")	
Rapid traverse (m/min)		X: 15, Z / W: 18	X / U: 15, Z / R / W: 18	X: 12, Z: 15, W: 10				
Servo motor (X ₁ / X ₂ -axis) (kW)		3			4			
Servo motor (Z ₁ / Z ₂ -axis) (kW)					4		7	
Servo motor (W-axis) (kW)					4		7	
Bed inclination		45°						
Weight (kg)		7500 (16500 lb)	11000 (24200 lb)	A: 18000 (39600 lb) B: 18050 (39710 lb) C: 18100 (39820 lb) D: 18150 (39930 lb) E: 18200 (40040 lb)	A: 20000 (44000 lb) B: 20050 (44110 lb) C: 20100 (44220 lb) D: 20150 (44330 lb) E: 20200 (44440 lb)	A: 22000 (48400 lb) B: 22050 (48510 lb) C: 22100 (48620 lb) D: 22150 (48730 lb) E: 22200 (48840 lb)	A: 24000 (52800 lb) B: 24050 (52910 lb) C: 24100 (53020 lb) D: 24150 (53130 lb) E: 24200 (53240 lb)	
Machine dimensions (mm)	W x H	2300 x 2300 (90.6" x 90.6")			3470 x 2840 (136.6"x111.8")		3595 x 2940 (141.5"x115.7")	
	L	5100 (200.8")	5600 (220.5")	5200 (204.7")	5600 (220.5")	6000 (236.2")	6600 (259.8")	

■ All data subject to change without notice.

■ All the specifications are listed with the FANUC CNC system.

Optional Accessories:

1. C-axis (C.S axis without gear box/C.F axis with gear box)
2. Contact tool setting system (Renishaw TS-20 or BULM NT-A2 / NT-A3)
3. Tool holders (VDI type)
4. 2 Path system manual guide *i* (0i TD / 31i -B)

CNC Control Specs



■ CNC system type

O: Std. △: Opt. -: Nil

Type	Model	HT-30 Series	HT-40/60/80/100 A,B,C,D,E
Fanuc 0i-TD			○
Fanuc 31i-B			△
Siemens 840D (572.5)			△
Siemens 840D (573.5)			△
Siemens 828D (PPU281)			△

■ Fanuc specifications

O: Std. △: Opt. -: Nil

	Item	Specifications	0iTD	31i-B	
Display unit	8.4" color LCD		○	-	
	10.4" color LCD		△	○	
Function	Data Server with 2GB CF card		△	△	
	NC program memory	1280M (512KB)	○	○	
	Conversational programming with graphic function	Manual guide 0i	0iTD	○	-
		Manual guide i	31i-B / 0iTD (10.4" LCD)	△	○
	No. of tool offset sets		64	99	
	No. of variable command sets		500	500	
Work coordinate system	G54~G59		○	○	



■ Siemens specifications

O: Std. △: Opt. -: Nil

	Item	Specifications	828D	840D
Operator Panel	10.4" color LCD		○	○
	15.1" color LCD		-	△
	Machine panel MCP483C		○	○
	TCU without hard disk	CF card	○	○
	Network/disk drive management		○	○
	PCU 50 with hard disk	Include HD & Ethernet	-	△
Function	ShopTurn programming (copy licence)		△	△
	Automatic residual material detection		△	△
	Transmit / Peripheral surface transformation		△	○
	Measuring cycles for drilling/milling and turning		△	△





**Whatever You Need
for Milling and Turning
We Offer The Best.**



ROUNDTOP MACHINERY INDUSTRIES CO., LTD.

No. 1056, Zhongshan Rd., Shengang Dist,

Taichung City 42955, Taiwan (R.O.C.)

Tel : 886-4-2562-4721

Fax: 886-4-2561-3886

<http://www.johnford.com.tw>

E-mail: johnford@johnford.com.tw