



MAGNA

Floor-type Milling Machine



Nicolás Correa, S.A.

Pol. Industrial de Itziar
20820 Deba · Guipúzcoa · Spain

Alcalde Martín Cobos, 16-A
09007 Burgos · Spain

Phone: +34 943 606 011

Phone: +34 947 288 100

Fax: +34 943 606 150

Fax: +34 947 288 117

correa@correa.es

correa@correa.es



www.correa.es



Septiembre 2015

correa

ENG

ROBUSTNESS

"Today's investment, tomorrow's saving"

Generously sized and properly ribbed structural parts, strong milling heads, machines in perfect geometry... have always been the distinctive features of **NICOLÁS CORREA** since its foundation in 1947.

We are convinced Robustness is a good bet for our customers, a sensible investment that will result in the following benefits/values:

RELIABILITY

In **NICOLÁS CORREA**, we extend the concept of robustness to the whole production process of the machine, always choosing technical solutions of the highest quality. For this reason, we offer as standard 5 year warranty on our milling machines.



PRECISION

The milling machine is stable and maintains geometry values longer.

DURABILITY

Our machines are designed and assembled to last for decades.
Tireless workers that maintain their chip removal capacity in good condition for years.

MILLING HEADS

Unique robust milling head technology with superb repeatability, flexible to perform roughing and finishing operations.

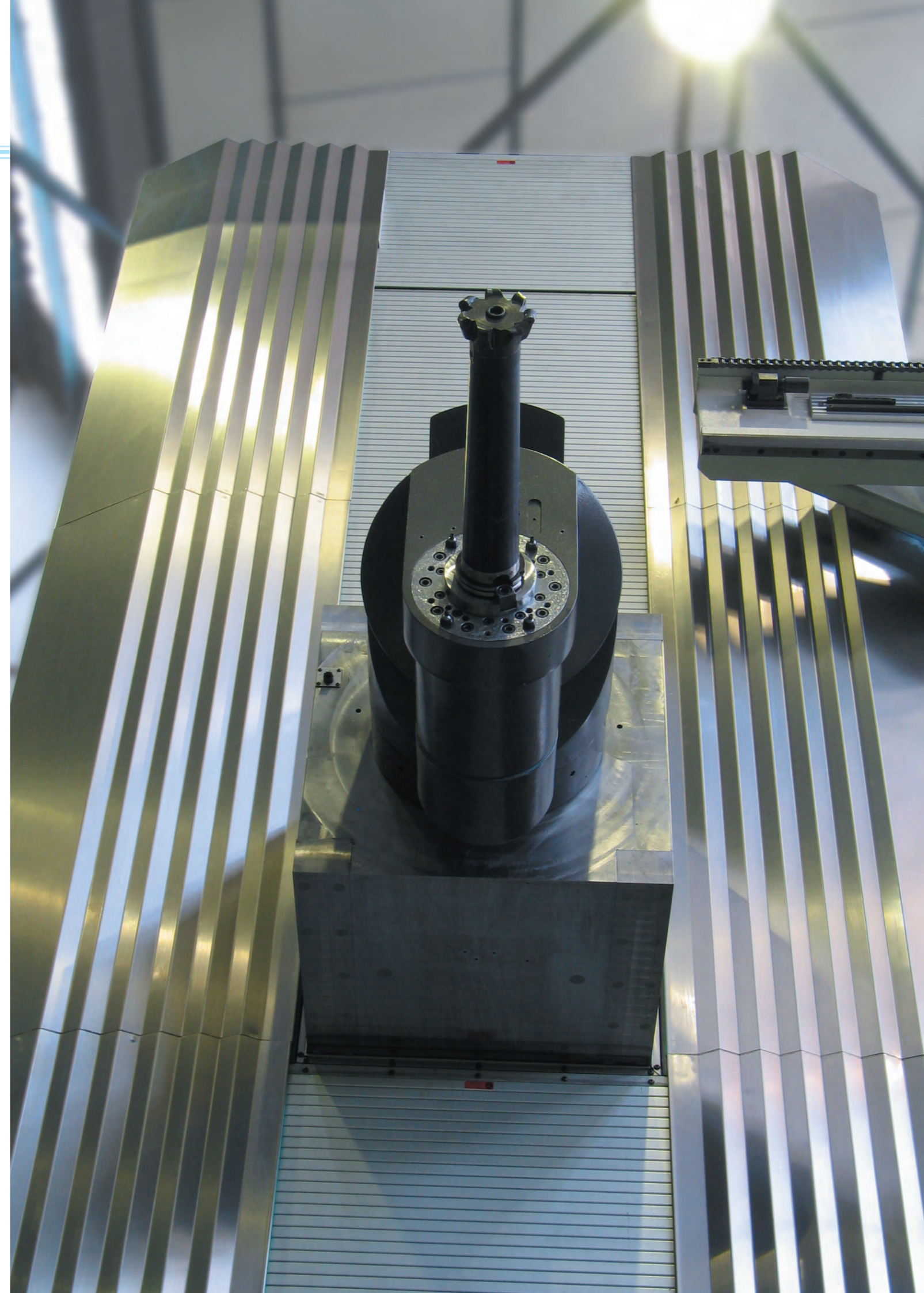

What makes the difference in the MAGNA?

The **MAGNA** represents the pure *box-in-box* concept, also incorporating two mechanical systems dynamically compensating for both ram droop and frame tipping. The result: tremendous chip removal capacity, maintaining very high levels of precision throughout the machine's volume

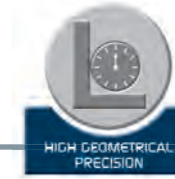
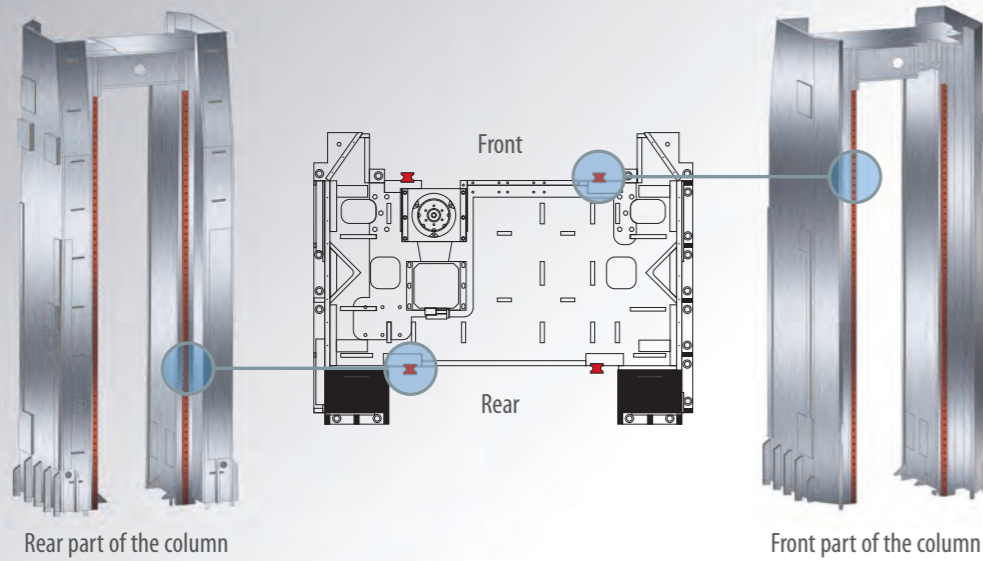

- Great cross sections
- Great roughing capacity
- Geometric stability in time

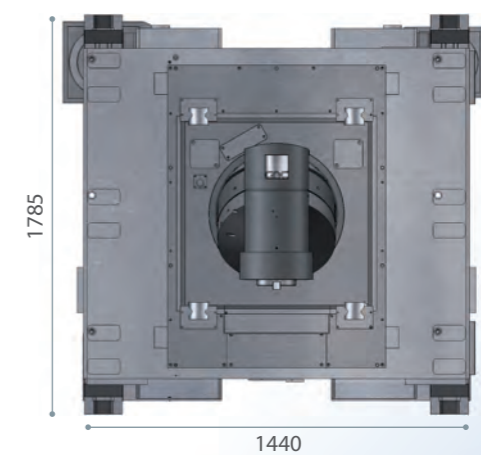
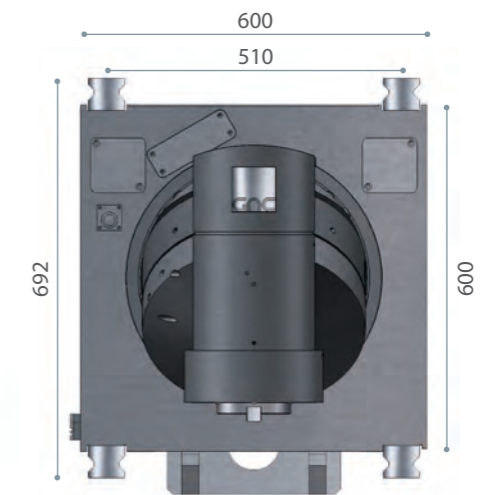
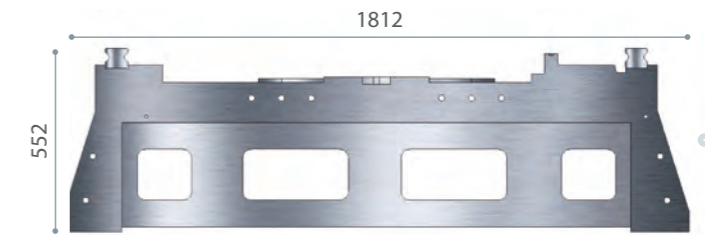

- Dynamic ram droop correction system
- Dynamic frame tipping compensation system

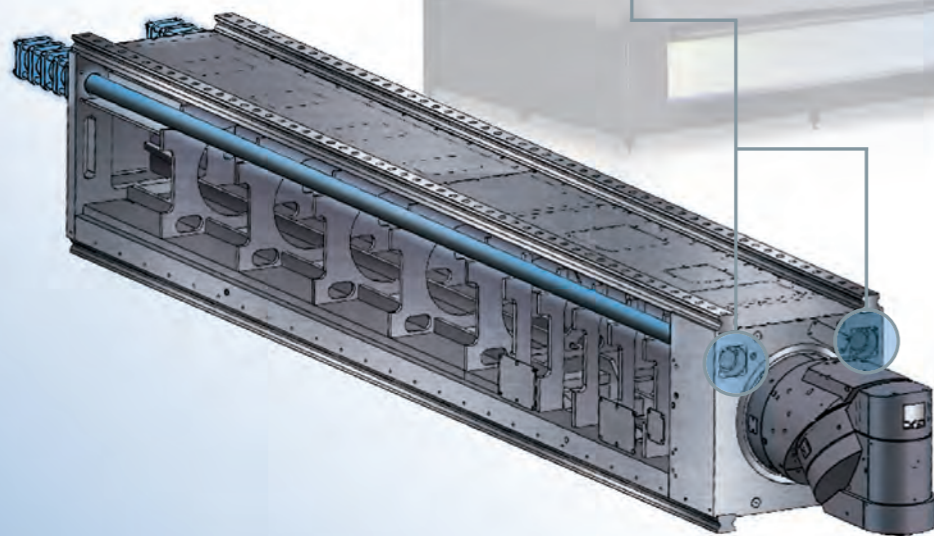

Stand-by function and Auto Switch off function, saving 20% of the total energy machine consumption



30 m/min in X, Y and Z axes, thanks to its V-Shaped linear guide-ways in all axes



Technical Features

MAGNA

TABLE

Surface	mm	3.500 - 25.000 x 2.000, 2.500, 3.000 x 300			
Maximum load on the table	Tn/m ²	10 / 15			
TRAVERSES					
Longitudinal	X mm	6.000 - 27.000			
Cross	Y mm	1.500 - 2.000			
Vertical	Z mm	4.000	5.000	6.000	7.000
FEEDS					
Maximum	X m/min	30			
	Y m/min	30			
	Z m/min	25	20	20	20
VERTICAL SPINDLE SPECIFICATIONS					
Spindle nose		ISO-50 HSK-100			
Programmable speed	rpm	4.000 / 6.000			
Maximum power	kW	52			
Maximum torque	Nm	1.375			

Standard Equipment

Automatic Universal Head
UGA (2,5° - 2,5°)

Numerical control Heidenhain i530
HSCI or Siemens 840D sl (Operate HMI)

Portable handwheel

Air-conditioned electrical cabinet

Linear guides in the X, Y and Z axes

Lamp in the working area

Hydraulic and cooling group

Linear scales in all axes

External Coolant with
adjustable nozzles in the head

Internal and
external air flow

Guarding

Tele-service

External Dimensions

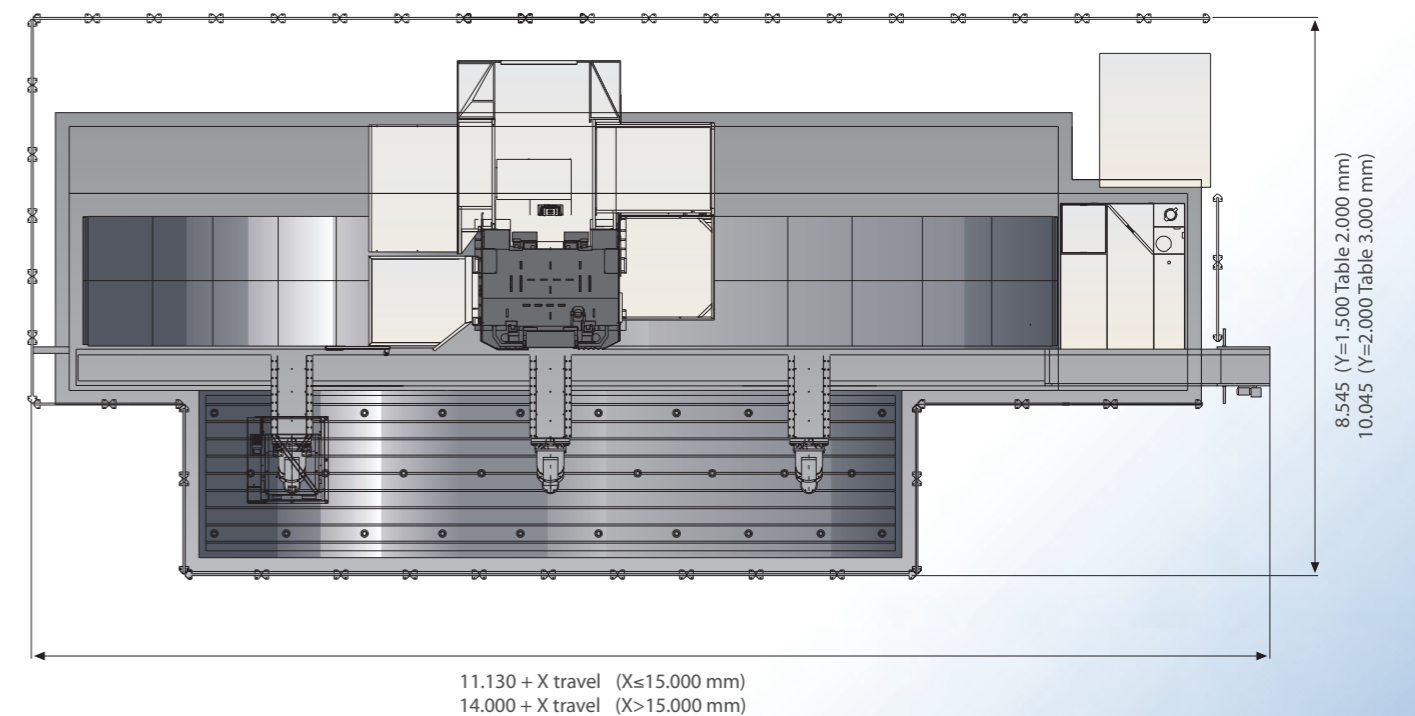
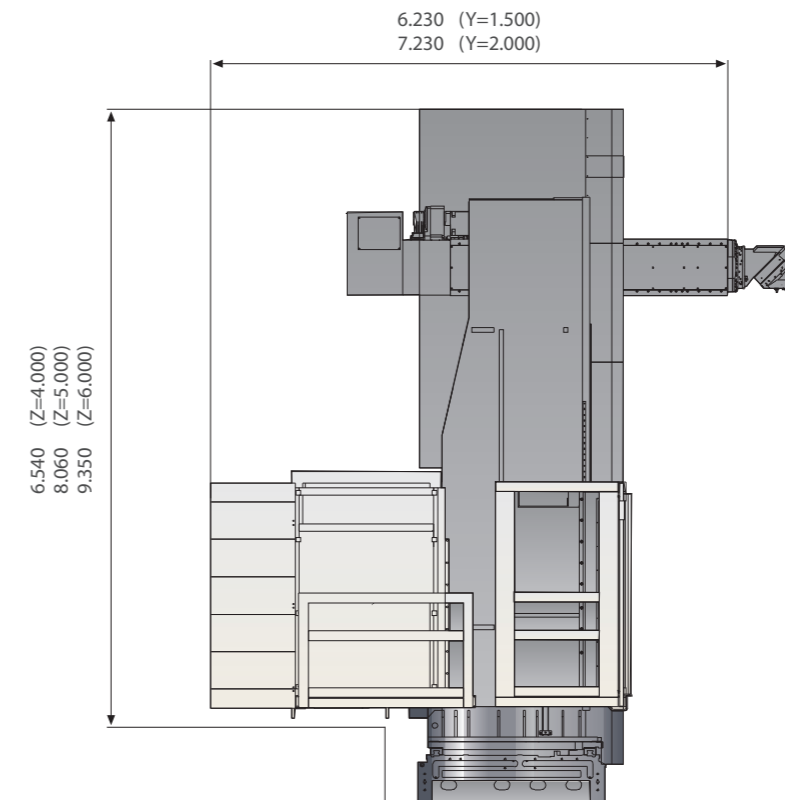

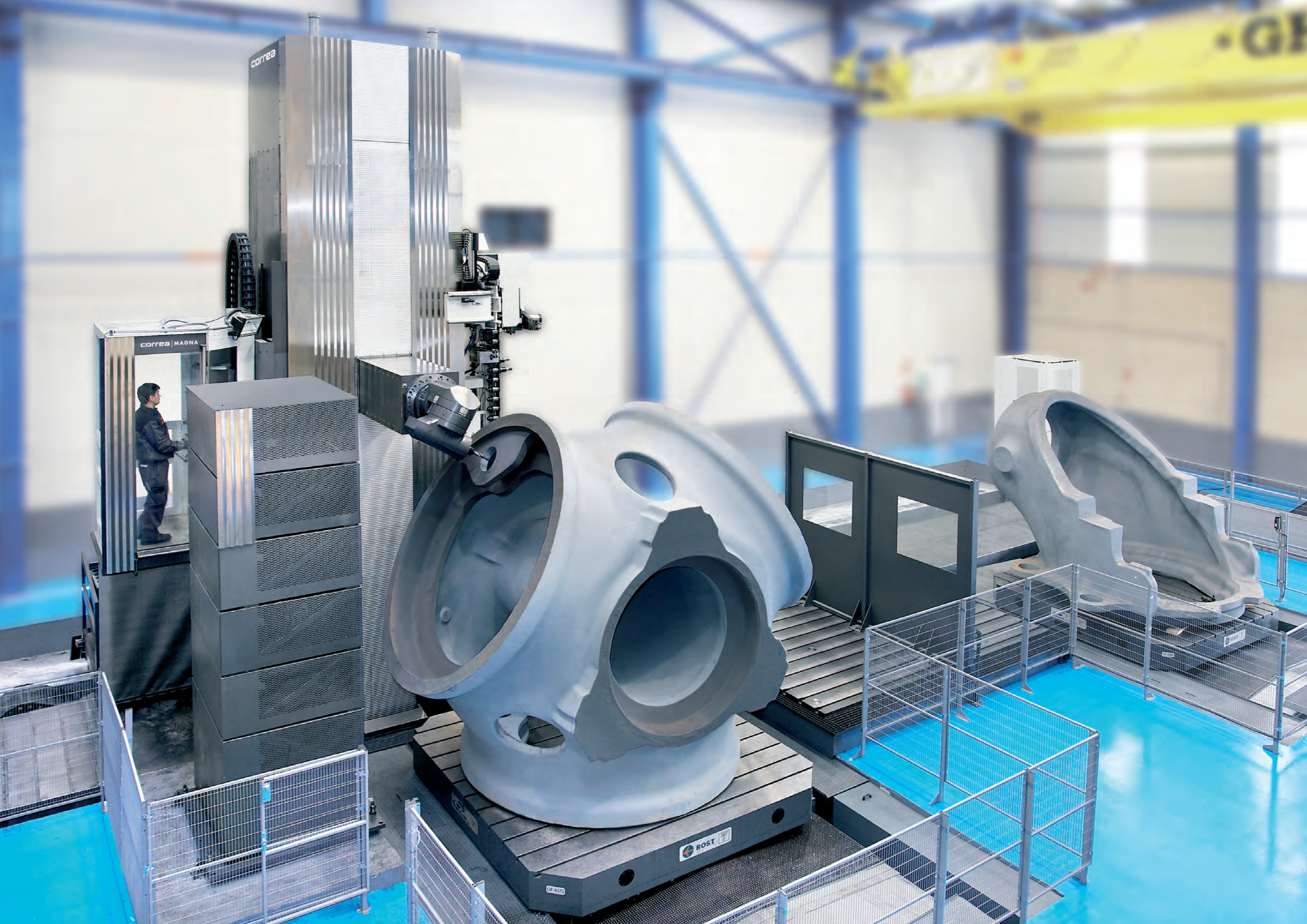

Unique Indexing Milling Head Technology

Patented worldwide

FLEXIBILITY

Rotation/indexation every **0,02°** thanks to the double Hirth coupling patented worldwide

6.000 rpm with no limitations

Adjustable coolant through spindle
17 - 70 bar

100% ROBUST

RELIABILITY

Design and fabrication entirely by NCSA. The whole assembly process is monitored by NCSA

Head assembly in a **cleanroom** with constant temperature 22°C

Milling head run in the **test bench** for **60 hours** performing body & spindle rotations

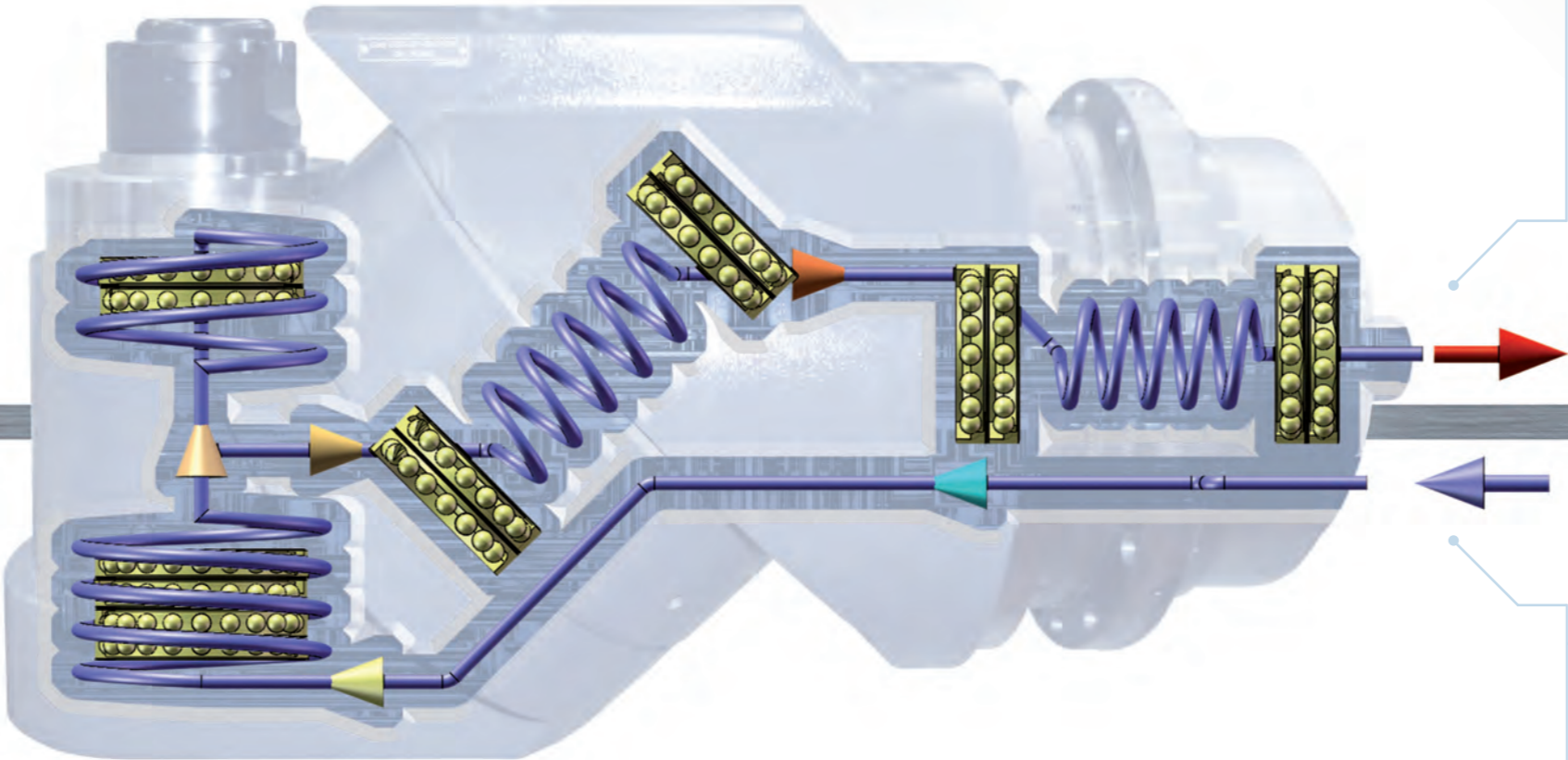

ROBUSTNESS

4+2 Bearings in the main spindle

Tool clamping force = **2.500 kg**

Hirth coupling's locking force = **22.000 kg**

The milling head's design allows **52 kW - 1.375 Nm** in S1

Milling head body made of **casted steel GGG-50**

100% RELIABLE

PRECISION

Maximum coupling repeatability error **+ - 3"**

The bearing's cages of the main spindle & the external spacers of the secondary axes' bearings, **are cooled with water**

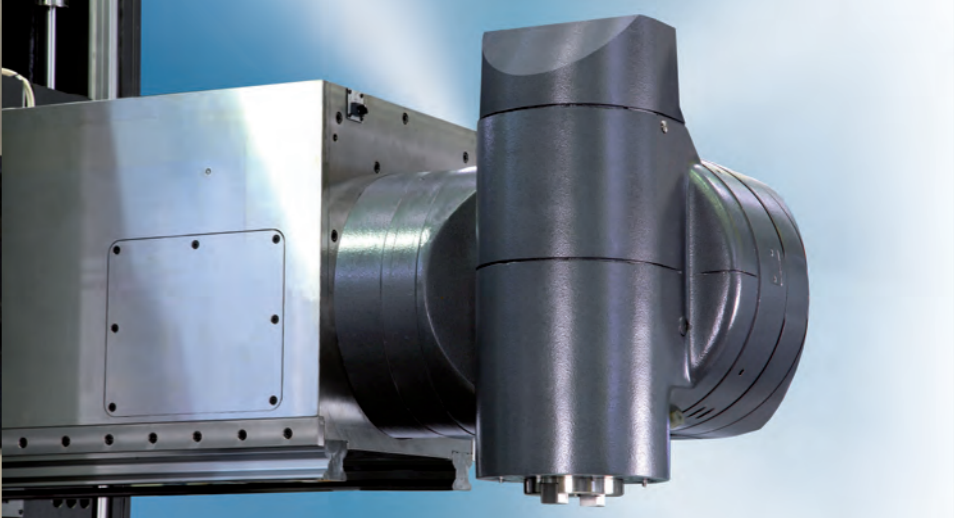

Milling Head

52 kW | 1.375 Nm | 6.000 rpm

Universal Auto-Indexing Differential Head

UAD 0.02° x 0.02°

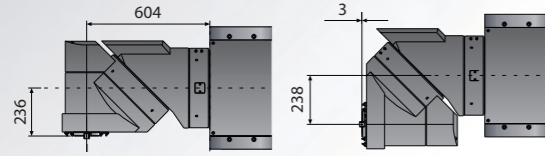

52 kW | 1.375 Nm | 4.000 rpm

Universal Auto-Indexing Differential Head

UGA 2.5° x 2.5°

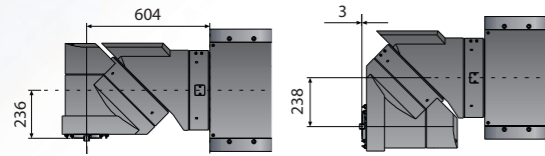

52 kW | 1.375 Nm | 6.000 rpm

Orthogonal Auto-Indexing Differential Head

OAD 0.02° x 0.02°

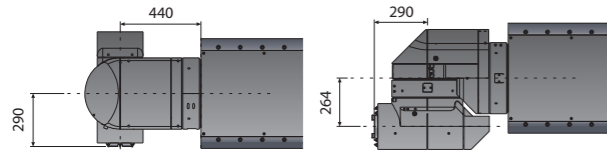

15 • 52 kW | 1.375 Nm | 3.000 • 4.000 rpm

Front Spindle

FC-20 | 30 | 60 | 80

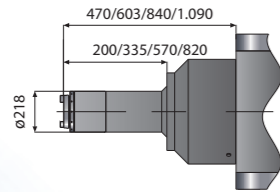

Milling Head

FD-20 | 30 | 60 | 80

Non-centered front spindle

15 • 52 kW | 1.375 Nm | 3.000 • 4.000 rpm

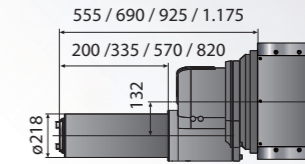
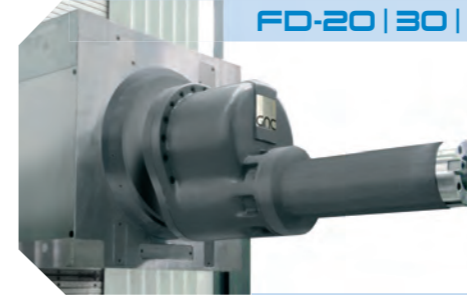

AL-600 2.5°

Reach-out Angle Milling Head

25 kW | 800 Nm | 1.500 rpm

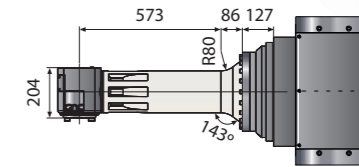

UT-500 | UT-630

D'Andrea Head

52 kW | 8.000 Nm | 315, 250 rpm

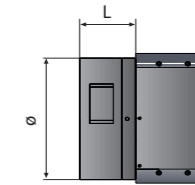

ESE Continuos

2-Axis continuous Milling Head

35 • 60 Kw | 12.000 • 24.000 rpm

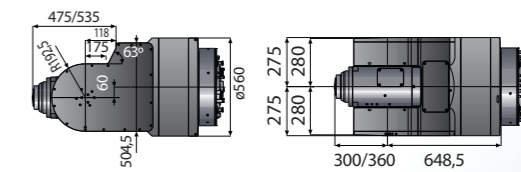
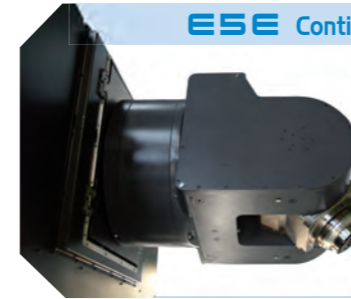

TU 2.5°

Turning and shaping Head

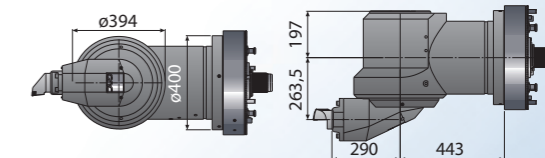

MILLING HEAD	AUTOMATIC HEAD EXCHANGE	BUILT IN
UAD	•	•
UGA	•	•
OAD	•	•
FC-20 30 60 80	•	•
FD-20 30 60 80	•	•
AL-600	•	•
UT-500 UT-630	•	•
ESE Continuos	•	•
TU	•	•

Milling Head Changer



Optional Equipment

Other heads

Automatic head-changer

Probes of measurement, tools and parts

Automatic charger for 30, 40, 60, 120 tools

Pick up station for 6, 8, 12 tools

Air/Coolant cleaning gun

Self cleaning filter

Floor plates

Rotary tables

Turning tables

Chip conveyors

Perimeter fence

Different enclosures according to user's needs (only in some models)

Coolant through spindle

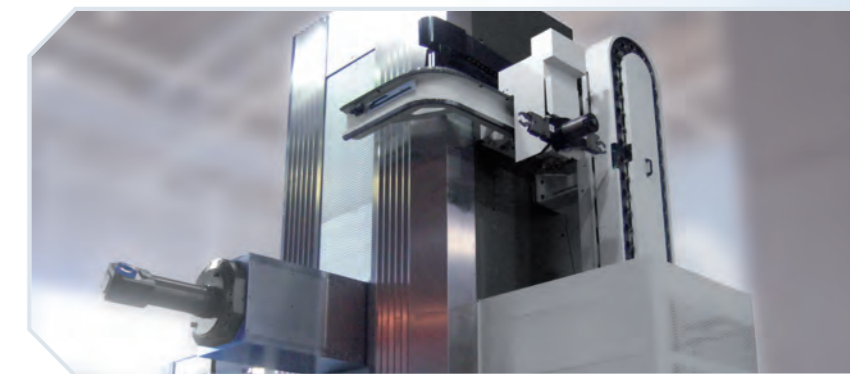
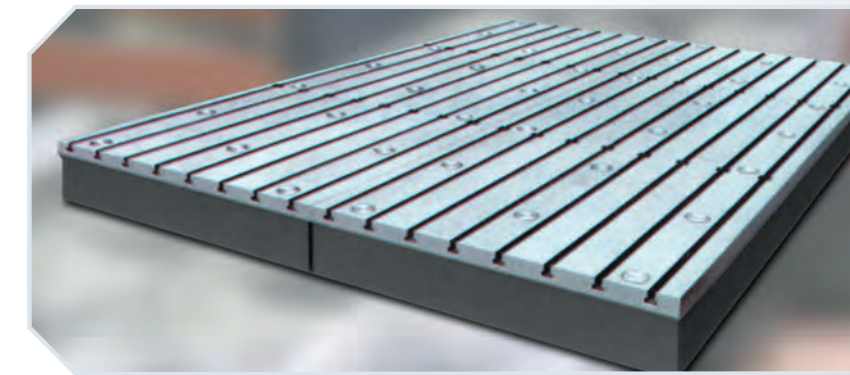
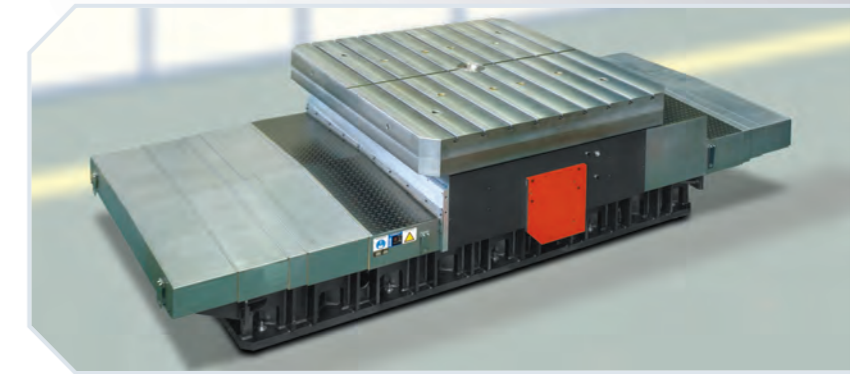

Applications



EQUIPMENT MACHINING (CRANES)

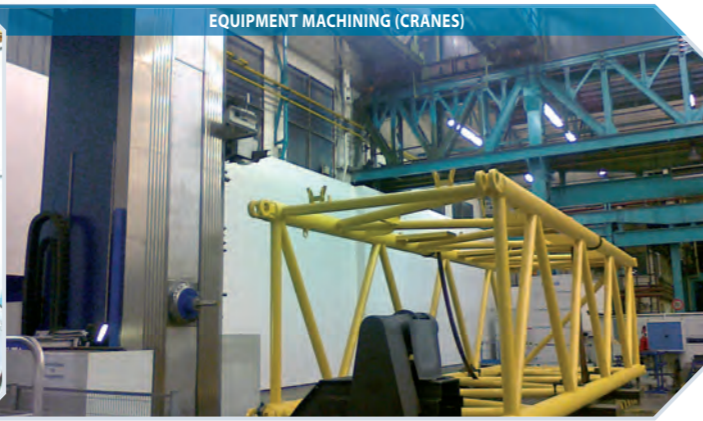

EQUIPMENT MACHINING (CRANES)

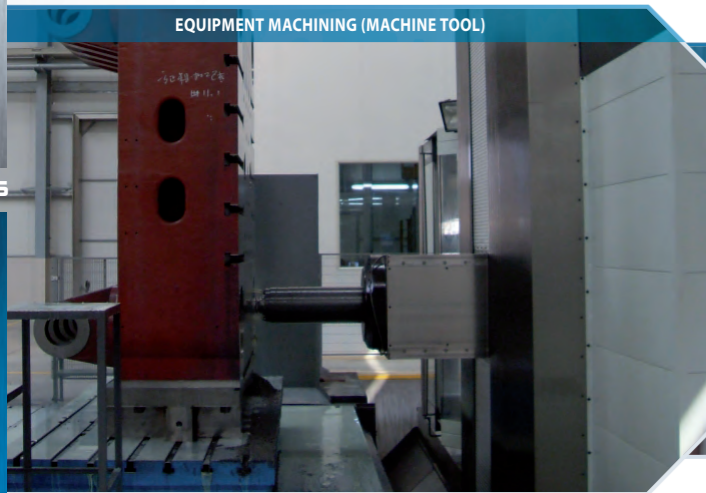

EQUIPMENT MACHINING (MACHINE TOOL)

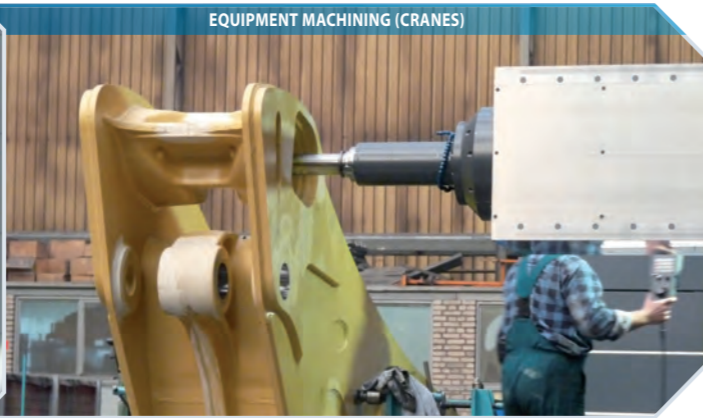

EQUIPMENT MACHINING (CRANES)



WIND POWER SECTOR MACHINING (HUB)

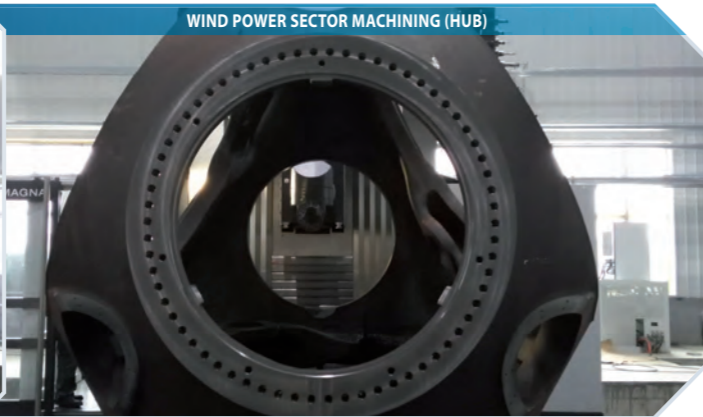

WIND POWER SECTOR MACHINING (HUB)

Applications



AUTOMOTIVE (INJECTION MOULD)



AUTOMOTIVE (INJECTION MOULD)



AERONAUTICAL (TOOLING)

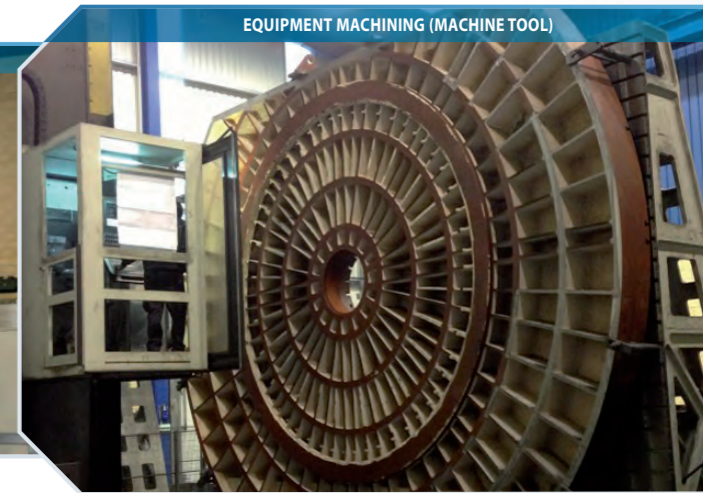

EQUIPMENT MACHINING (MACHINE TOOL)

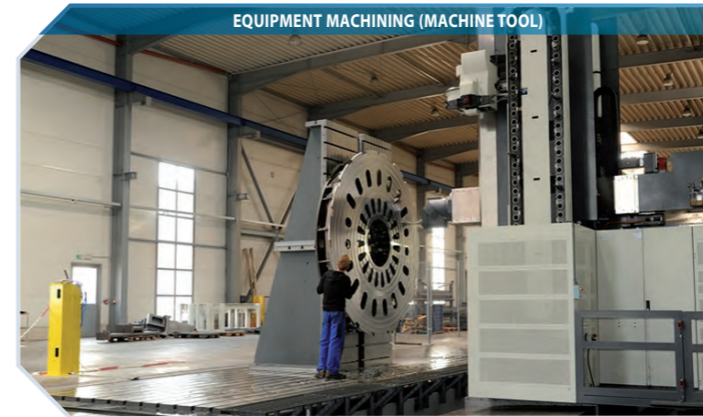

EQUIPMENT MACHINING (MACHINE TOOL)



HEAT EXCHANGER MACHINING



NICOLÁS CORREA S.A.

Founded in 1947 and dedicated to the design and fabrication of medium and large size milling machines, is the headquarters of the Group **NICOLÁS CORREA** also formed by 4 other industrial affiliates:

GNC HYPATIA

Design and fabrication of **CORREA** milling machines of small size, as well as accessories for the tool machine industry such as ATCs and milling heads.

GNC KUNMING

Fabrication and distribution of milling machines for the local chinese market.

GNC ELECTRÓNICA

Design and fabrication of electrical assemblies.

GNC CALDERERÍA

Welded structures, sheet parts, and machine guarding systems.

Some critical components are supplied inside the group to assure quality and fulfill the flexibility requirements of our customers.

In 2006 **NICOLÁS CORREA** and **INDUSTRIAS ANAYAK** merged, what gave us the chance to offer one of the widest milling machine ranges on the market including: bed type (Also T-Configuration), Travelling column (Also T-Configuration), Portal milling machines. The design and manufacture are entirely made in Europe.

It quotes in the Madrid Stock Exchange since 1989.

In order to guarantee service and personal assistance to our customers, we have a wide sales and service network all over the world, being present through subsidiaries or agents in most of the countries.

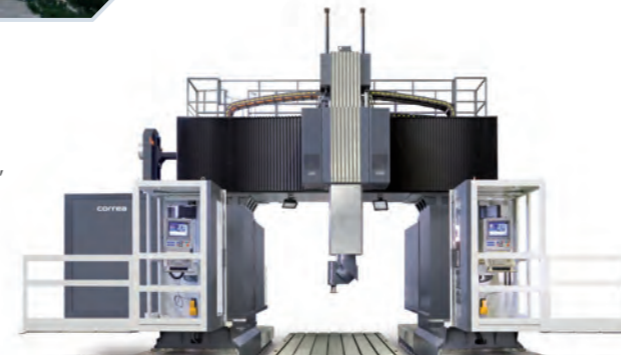

FOX-M

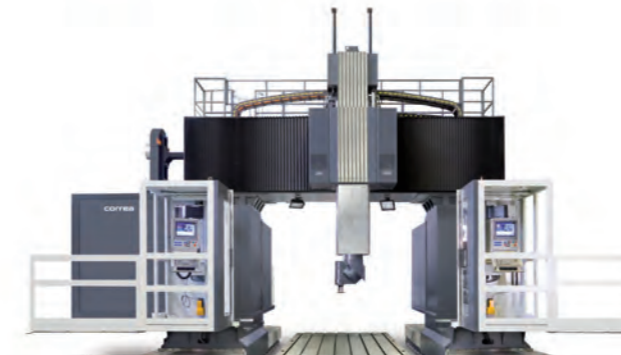

VERSA-M



VERSA-MW



FOX



VERSA



VERSA-W



NORMA-L



NORMA-FT

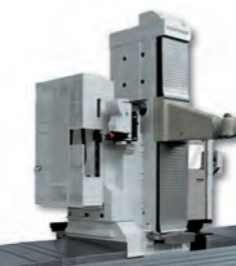

HVM



AXIA



MAGNA



XPERTA

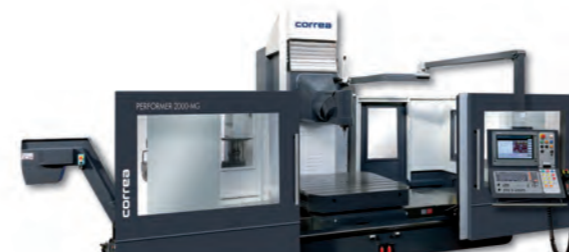

PERFORMER-MG



NORMA



VH-PLUS-MG



HVM-LANZA



VH-PLUS LANZA

BORING MACHINES

GANTRY TYPE

BRIDGE TYPE

TRAVELLING COLUMN

BED TYPE