

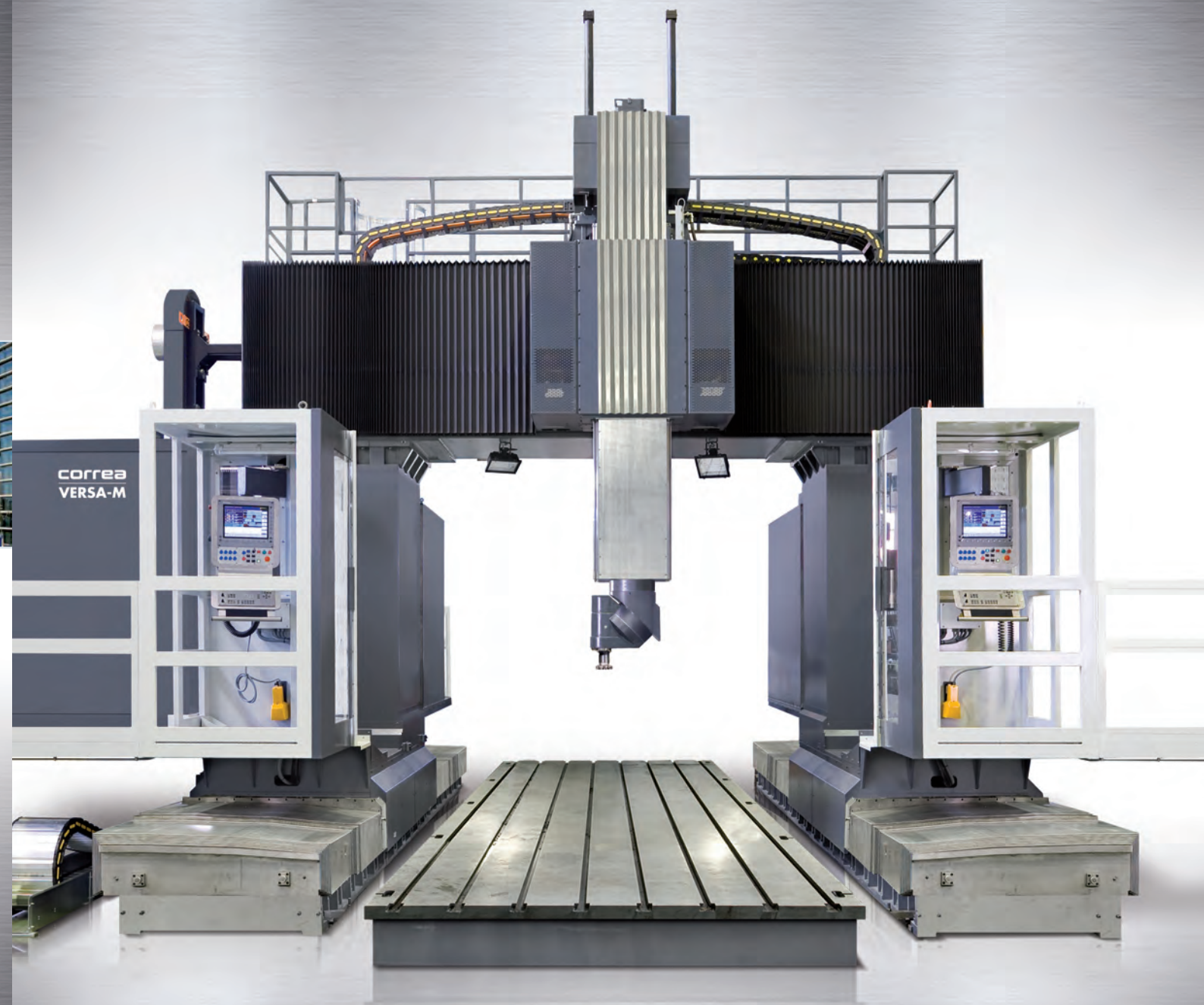

VERSA·M | VERSA·MW

High Performance Gantry-type Milling Machine



correa

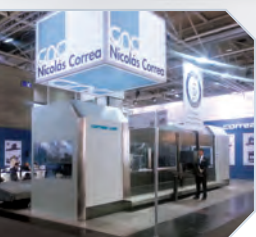

Nicolás Correa, S.A.

Pol. Industrial de Itziar
20820 Deba · Guipúzcoa · Spain

Phone: +34 943 606 011
Fax: +34 943 606 150

correa@correa.es



Alcalde Martín Cobos, 16-A
09007 Burgos · Spain



Phone: +34 947 288 100
Fax: +34 947 288 117



correa@correa.es



www.correa.es



Septiembre 2015

ENG

ROBUSTNESS

"Today's investment, tomorrow's saving"

Generously sized and properly ribbed structural parts, strong milling heads, machines in perfect geometry... have always been the distinctive features of **NICOLÁS CORREA** since its foundation in 1947.

We are convinced Robustness is a good bet for our customers, a sensible investment that will result in the following benefits/values:

RELIABILITY

In **NICOLÁS CORREA**, we extend the concept of robustness to the whole production process of the machine, always choosing technical solutions of the highest quality. For this reason, we offer as standard 5 year warranty on our milling machines.



PRECISION

The milling machine is stable and maintains geometry values longer.

DURABILITY

Our machines are designed and assembled to last for decades.
Tireless workers that maintain their chip removal capacity in good condition for years.

MILLING HEADS

Unique robust milling head technology with superb repeatability, flexible to perform roughing and finishing operations.



What makes the difference in the **VERSA-M**?

The **VERSA-M** represents the concept of a high performance Gantry machine. Its structural design and thermal symmetry permit the machining of large parts while maintaining high dynamics and chip removal

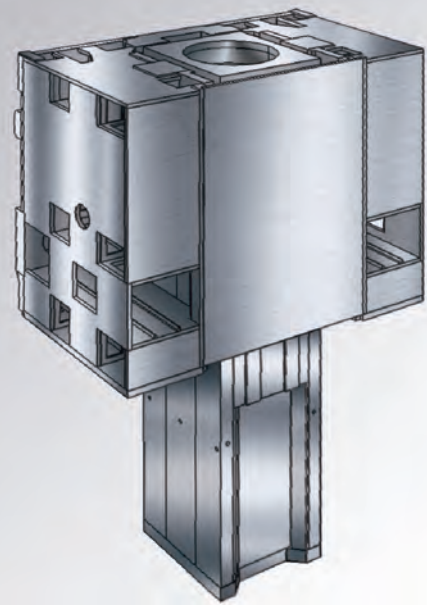

- Symmetrically guided ram
- Ram symmetrically centred over chassis
- Improved geometric performance faced with temperature variations in the workshop

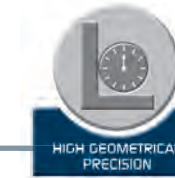

- Great cross sections
- Great roughing capacity
- Geometric stability in time

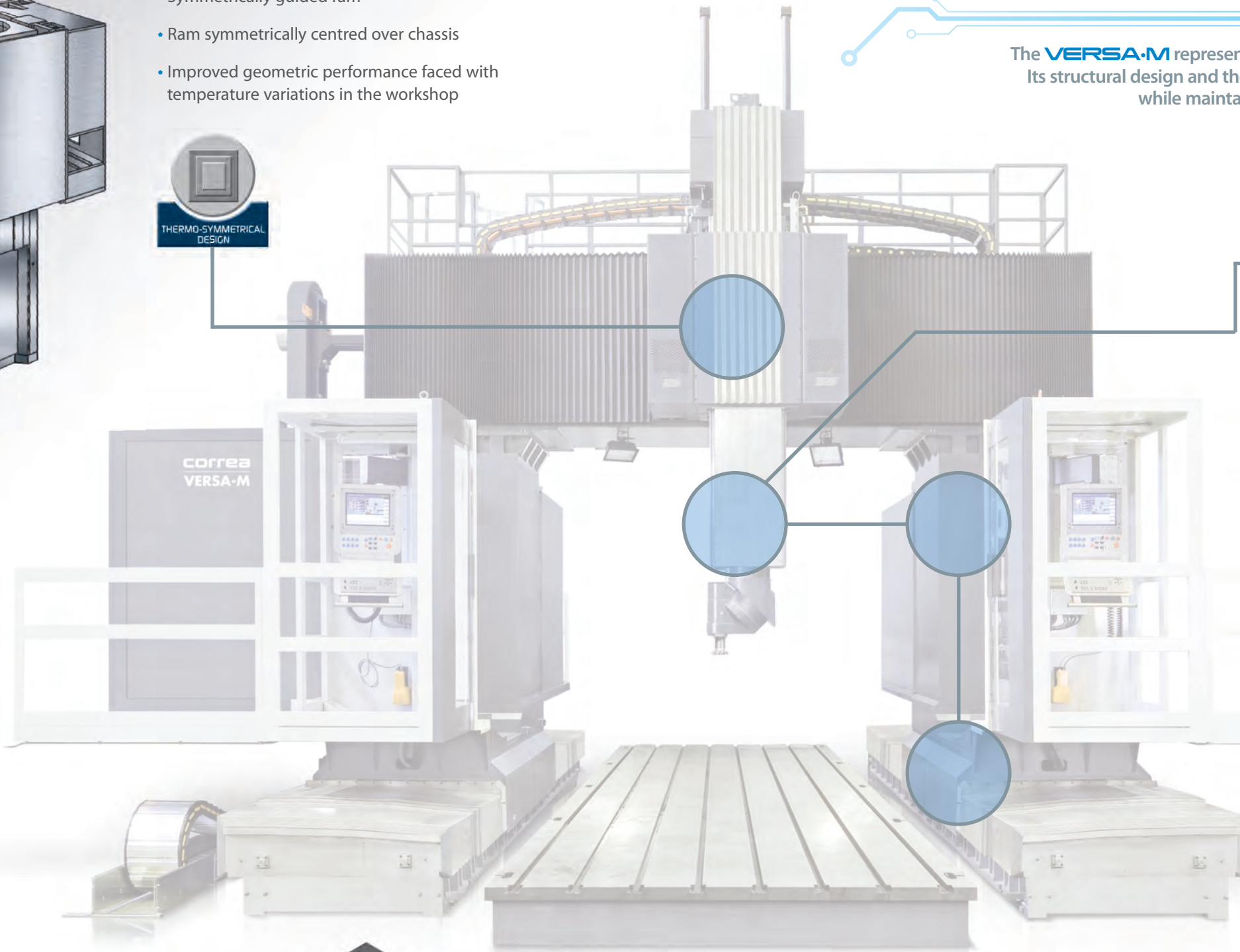
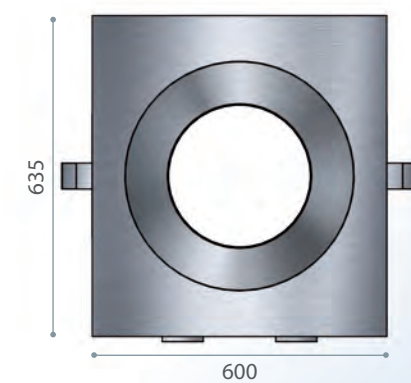
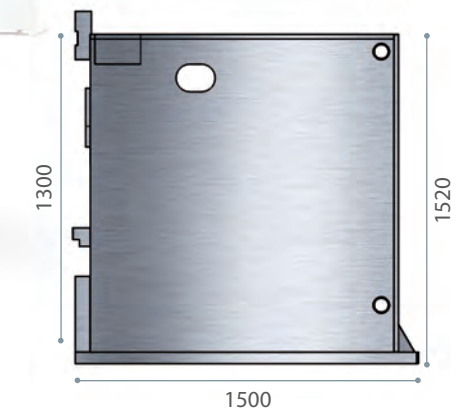
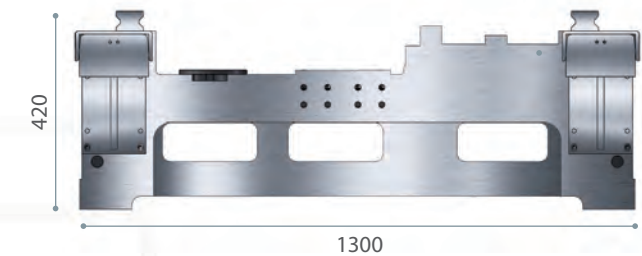

Stand-by function and Auto Switch off function, saving 20% of the total energy machine consumption



30 m/min in X, Y and Z axes, thanks to its V-Shaped linear guide-ways in all axes

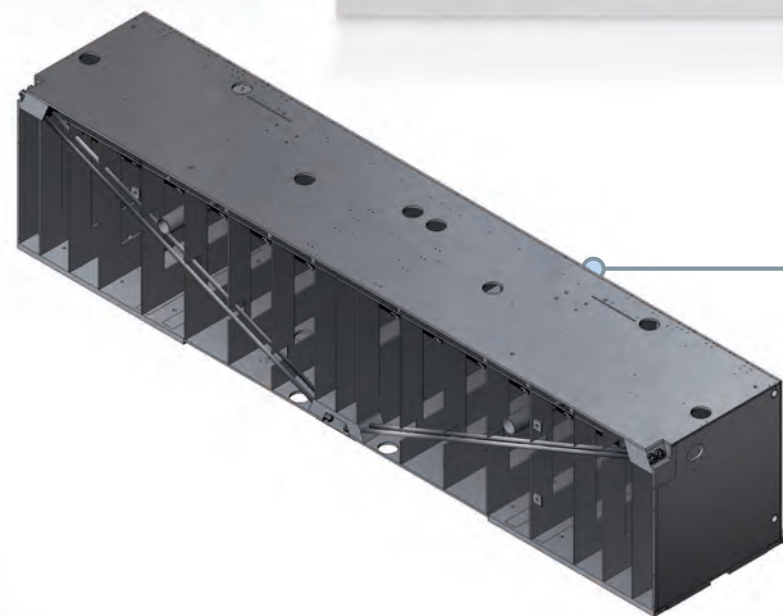

In all the **VERSA** and **FOX** type models

- Steel tie-rods inside the crossbeam
- Minimises deformation due to bending and flexing of the crossbeam
- Improved machine geometry
- Enhanced roughing capacity

What makes the difference in the **VERSA·MW**?

The **VERSA·MW** represents the concept of a high-performance Gantry - **W** machine. Its structural design and thermal symmetry combined with a **W** axis, unique in the market, make this machine the ideal solution for machining high volumes, keeping a high level of dynamics and chip removal

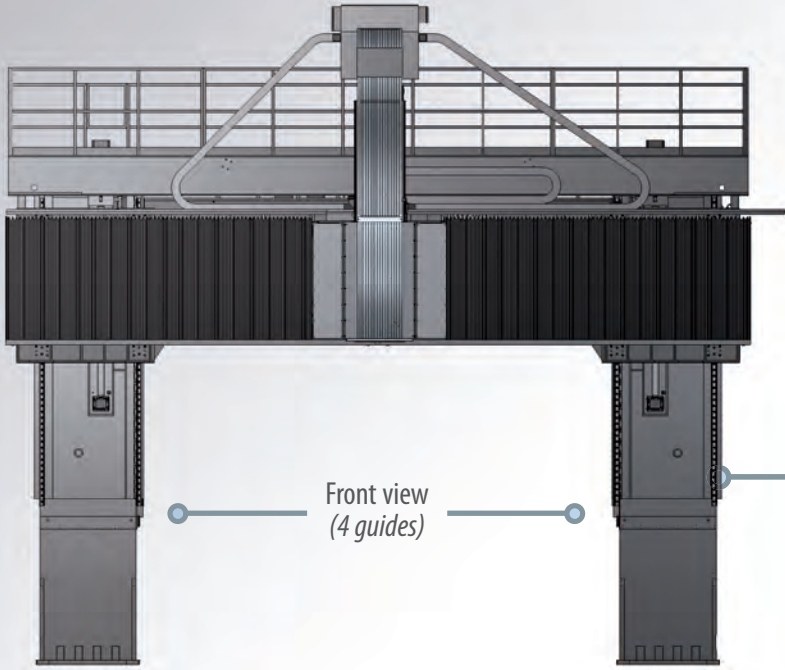

Close-up of **W** guide
(6 guides)

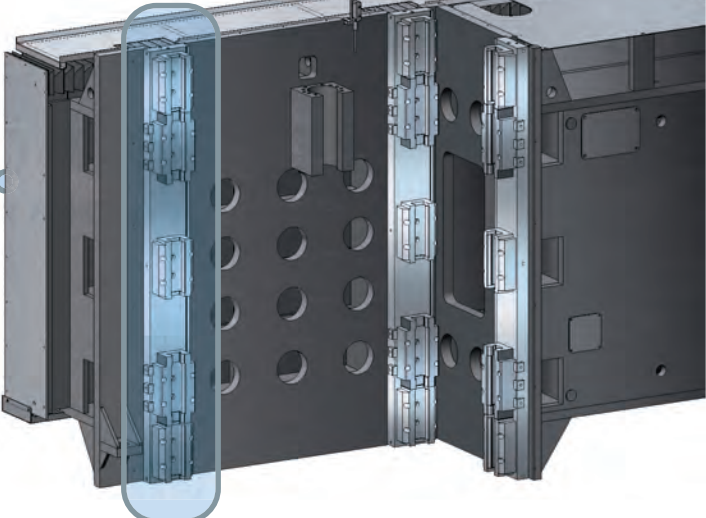

Locking force: 2270 N x 18
Units: 40080 N

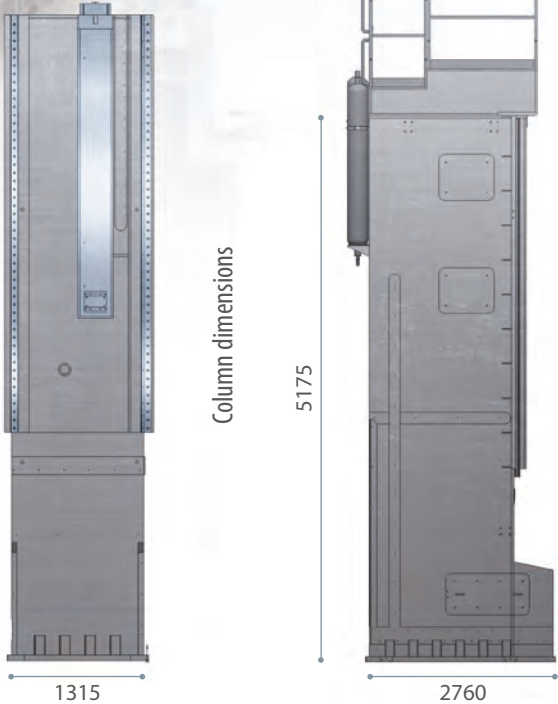
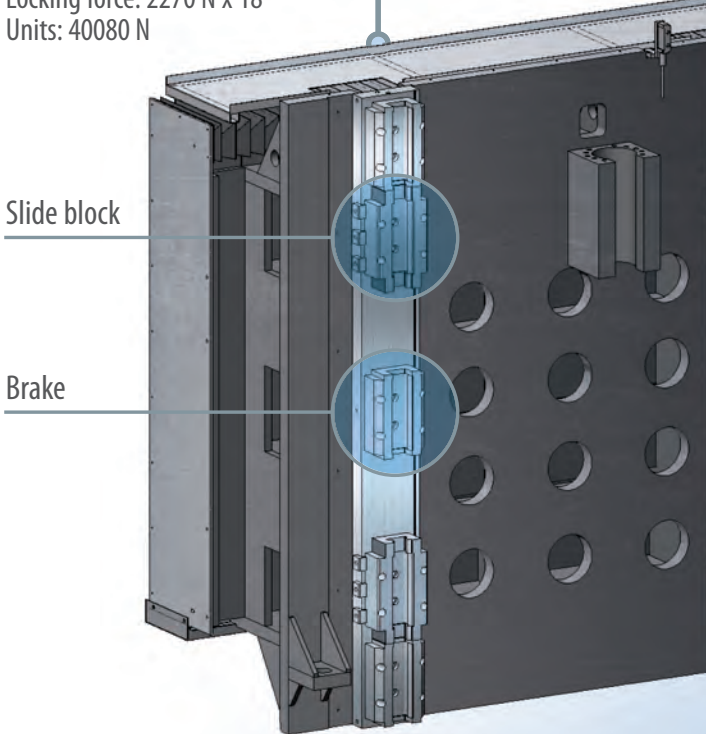

W is a live axis!!!
Great roughing capacity and geometric precision

Technical Features

VERSA·M							
TABLE							
Surface	mm	10.000 - 25.000 x 2.500, 3.000, 3.500					
Maximum load on the table	kg/m ²	10.000, 15.000					
TRAVERSES							
Longitudinal	X mm	9.500 - 30.500					
Cross	Y mm	3.500	4.000	4.500	5.000	6.000	7.000
Vertical	Z mm	1.000, 1.250, 1.500, 2.000					
WORK CAPACITY							
Distance between columns	mm	3.300	3.800	4.300	5.300	6.300	
Distance table-crossbeam	mm	2.205, 2.705					
FEEDS							
Maximum	X m/min	30					
	Y m/min	30					
	Z m/min	30					
SPINDLE SPECIFICATIONS							
Spindle nose		ISO-50 BT-50 HSK-100					
Programmable speed	rpm	4.000 / 6.000					
Maximum power	kW	52					
Maximum torque	Nm	1.375					

Standard Equipment

Automatic Universal Head
UGA (2,5° - 2,5°)

Numerical control Heidenhain i530
HSCI or Siemens 840D sl (Operate HMI)

Portable handwheel

Air-conditioned electrical cabinet

Linear guides in the X, Y and Z axes

Lamp in the working area

Hydraulic and cooling group

Linear scales in all axes

External Coolant with
adjustable nozzles

Internal and
external air flow

Guarding

Tele-service

Technical Features

VERSA·MW				
TABLE				
Surface	mm	10.000 - 25.000 x 2.500, 3.000, 3.500		
Maximum load on the table	kg/m ²	10.000, 15.000		
TRAVERSES				
Longitudinal	X mm	9.500 - 30.500		
Cross	Y mm	4.800	—	6.800
Vertical	Z mm	1.500, 2.000, 5.800		
	W mm	2.500, 3.500		
WORK CAPACITY				
Distance between columns	mm	3.600	4.600	5.600
Distance table-crossbeam	mm	3.675, 4.675		
FEEDS				
Maximum	X m/min	30		
	Y m/min	30		
	Z m/min	30		
SPINDLE SPECIFICATIONS				
Spindle nose		ISO-50 BT-50 HSK-100		
Programmable speed	rpm	4.000 / 6.000		
Maximum power	kW	52		
Maximum torque	Nm	1.375		

Standard Equipment

Automatic Universal Head
UGA (2,5° - 2,5°)

Numerical control Heidenhain i530
HSCI or Siemens 840D sl (Operate HMI)

Portable handwheel

Air-conditioned electrical cabinet

Linear guides in the X, Y and Z axes

Lamp in the working area

Hydraulic and cooling group

Linear scales in all axes

External Coolant with
adjustable nozzles

Internal and
external air flow

Guarding

Tele-service

External Dimensions

VERSA·M

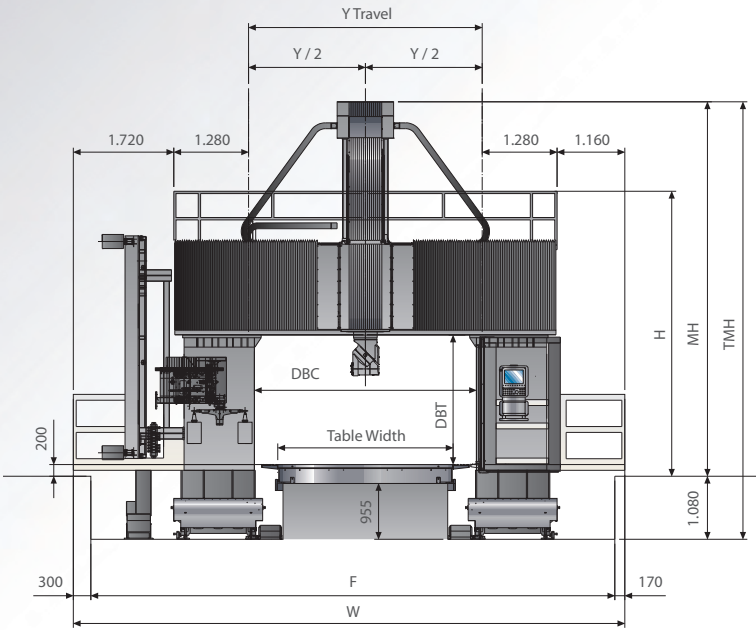

Y Travel	DBC	F	W	Max. Table Width
3.500				
4.000	3.300	8.320	8.920	2.500
4.000				
4.500	3.800	8.820	9.420	3.000
4.500				
5.000	4.300	9.320	9.920	3.500
6.000	5.300	10.320	10.920	4.500
7.000	6.300	11.320	11.920	5.500

X Travel	A	B	C
9.500	12.000	15.420	19.970
12.500	15.000	18.720	23.270
15.500	18.000	22.550	27.100
18.500	21.000	26.860	31.410
21.500	24.000	30.600	35.150
24.500	27.000	33.900	38.450
27.500	30.000	37.620	42.170
30.500	33.000	41.360	45.910

Z Travel	Vert. capacity	DBT	H	MH	TMH
1.000	A	2.205	4.900	6.150	7.300
1.250	A	2.205	4.900	6.400	7.550
1.500	A	2.205	4.900	6.650	7.800
	B	2.705	5.400	7.150	8.300
2.000	B	2.705	5.400	7.650	8.800

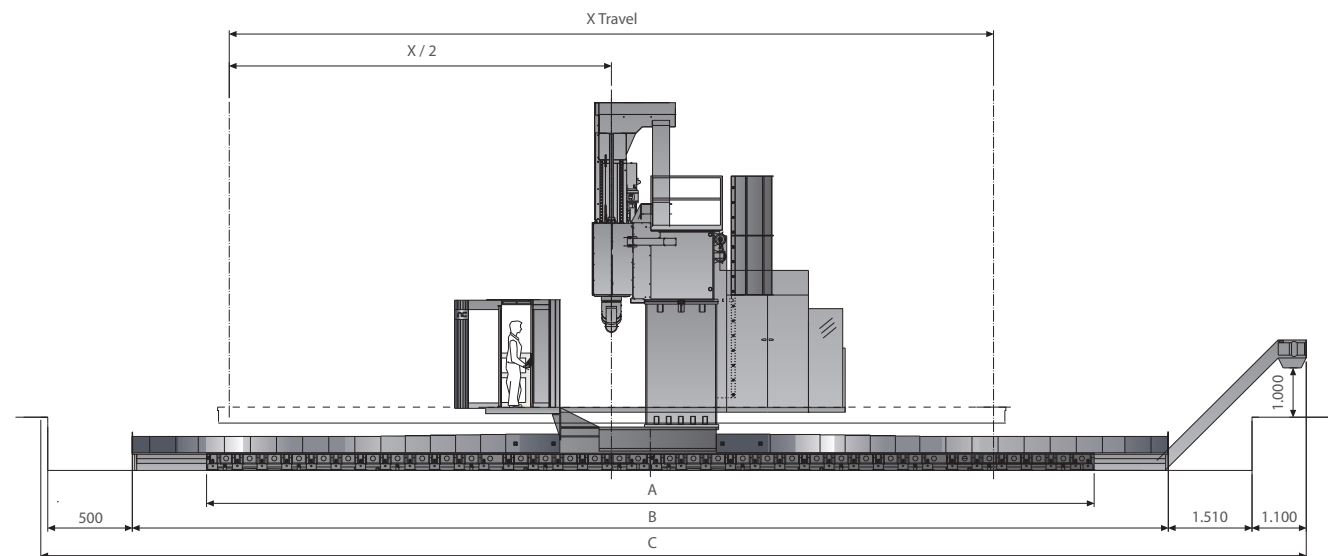

External Dimensions

VERSA·MW

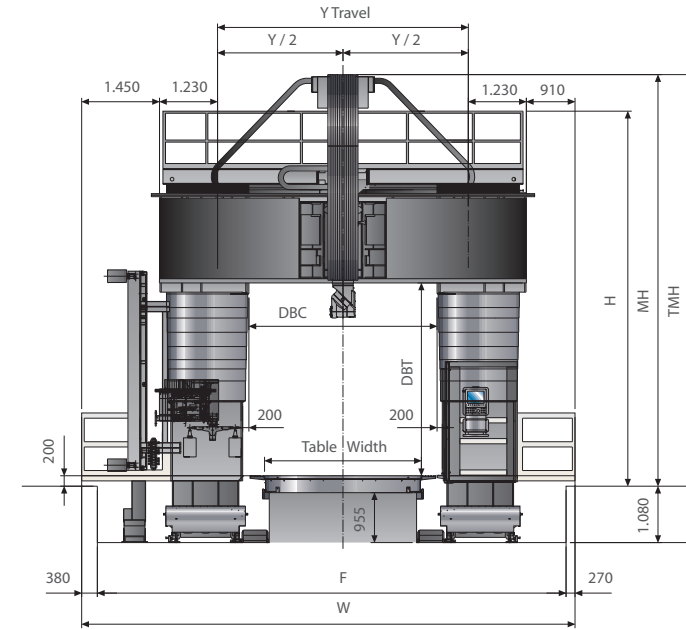

Y Travel	DBC	F	W	Max. Table Width
4.800	3.600	9.150	9.620	3.000
5.800	4.600	10.150	10.620	4.000
6.800	5.600	11.150	11.620	5.000

X Travel	A	B	C
8.500	12.000	15.420	19.970
11.500	15.000	18.720	23.270
14.500	18.000	22.550	27.100
17.500	21.000	26.860	31.410
20.500	24.000	30.600	35.150
23.500	27.000	33.900	38.450
26.500	30.000	37.620	42.170
29.500	33.000	41.360	45.910

W Travel	Z Travel	AVT	Vertical capacity	DBT_M	DBT_m	H	MH	TMH
2.500	1.500	3.000	A	3.675	1.175	7.400	8.300	9.450
	2.000					7.900	8.800	9.950
3.500	1.500	4.000	B	4.675	1.175	9.300	9.400	10.550
	2.000					9.300	9.900	11.050

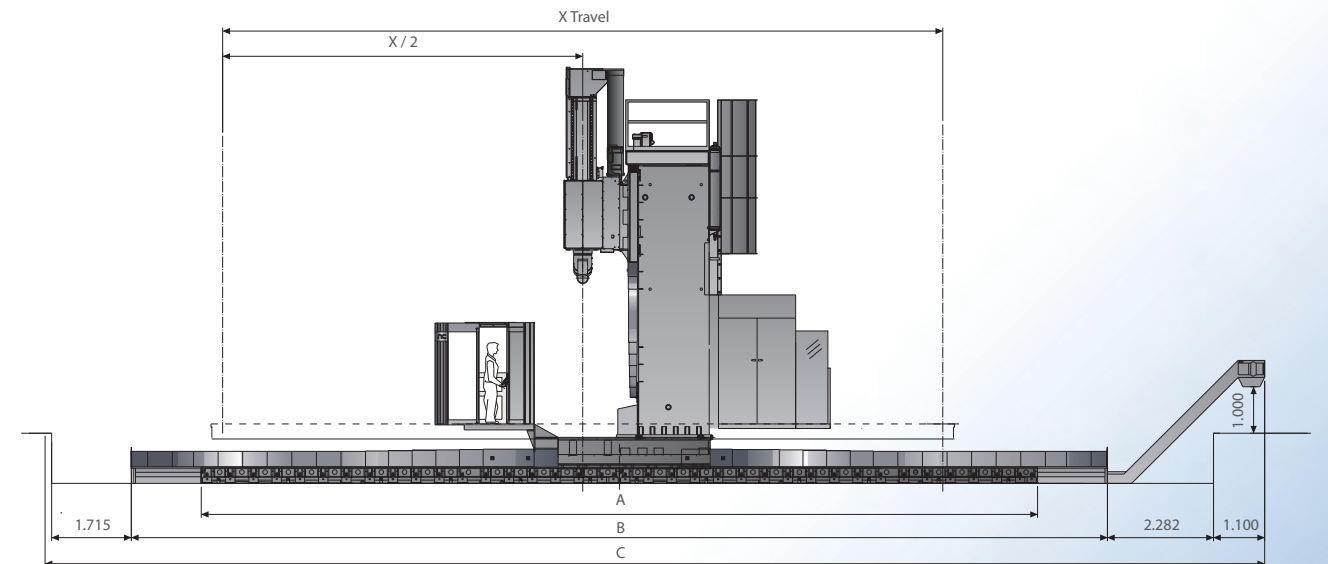



correa
VERSA-MW

Unique Indexing Milling Head Technology

Patented worldwide

FLEXIBILITY

Rotation/indexation every **0,02°** thanks to the double Hirth coupling patented worldwide

6.000 rpm with no limitations

Adjustable coolant through spindle
17 - 70 bar

ROBUSTNESS

4+2 Bearings in the main spindle

Tool clamping force = **2.500 kg**

Hirth coupling's locking force = **22.000 kg**

The milling head's design allows
52 kW - 1.375 Nm in S1

Milling head body made of
casted steel GGG-50

100% ROBUST

100% RELIABLE

RELIABILITY

Design and fabrication entirely by NCSA. The whole assembly process is monitored by NCSA

Head assembly in a **cleanroom** with constant temperature 22°C

Milling head run in the **test bench** for **60 hours** performing body & spindle rotations

PRECISION

Maximum coupling repeatability error **+ - 3"**

The bearing's cages of the main spindle & the external spacers of the secondary axes' bearings, **are cooled with water**

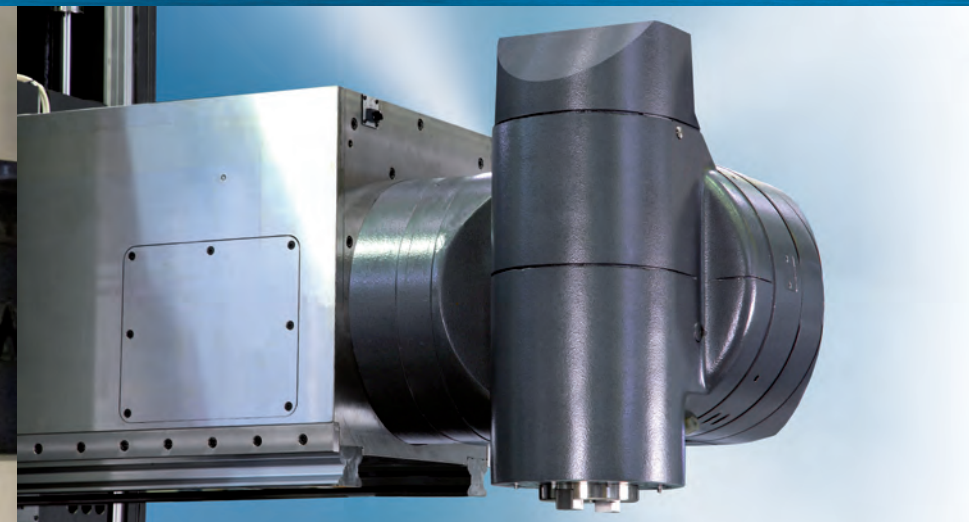
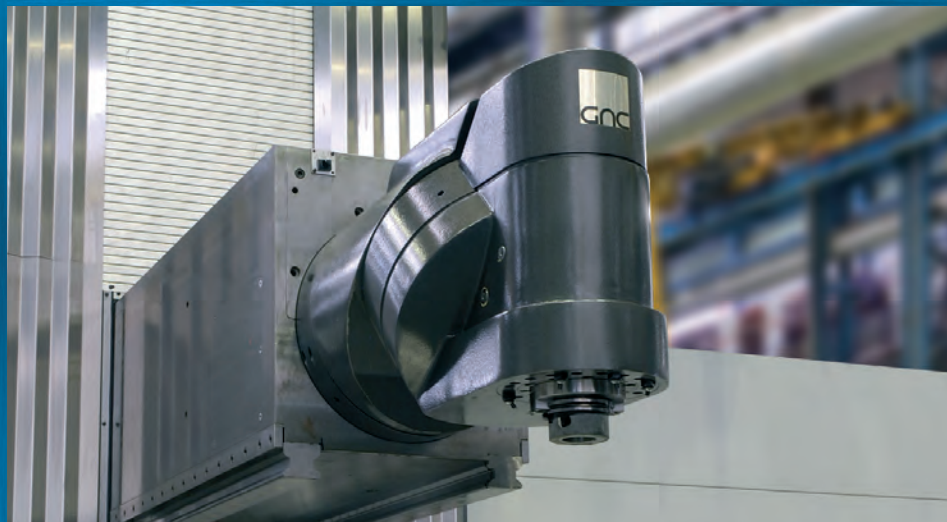
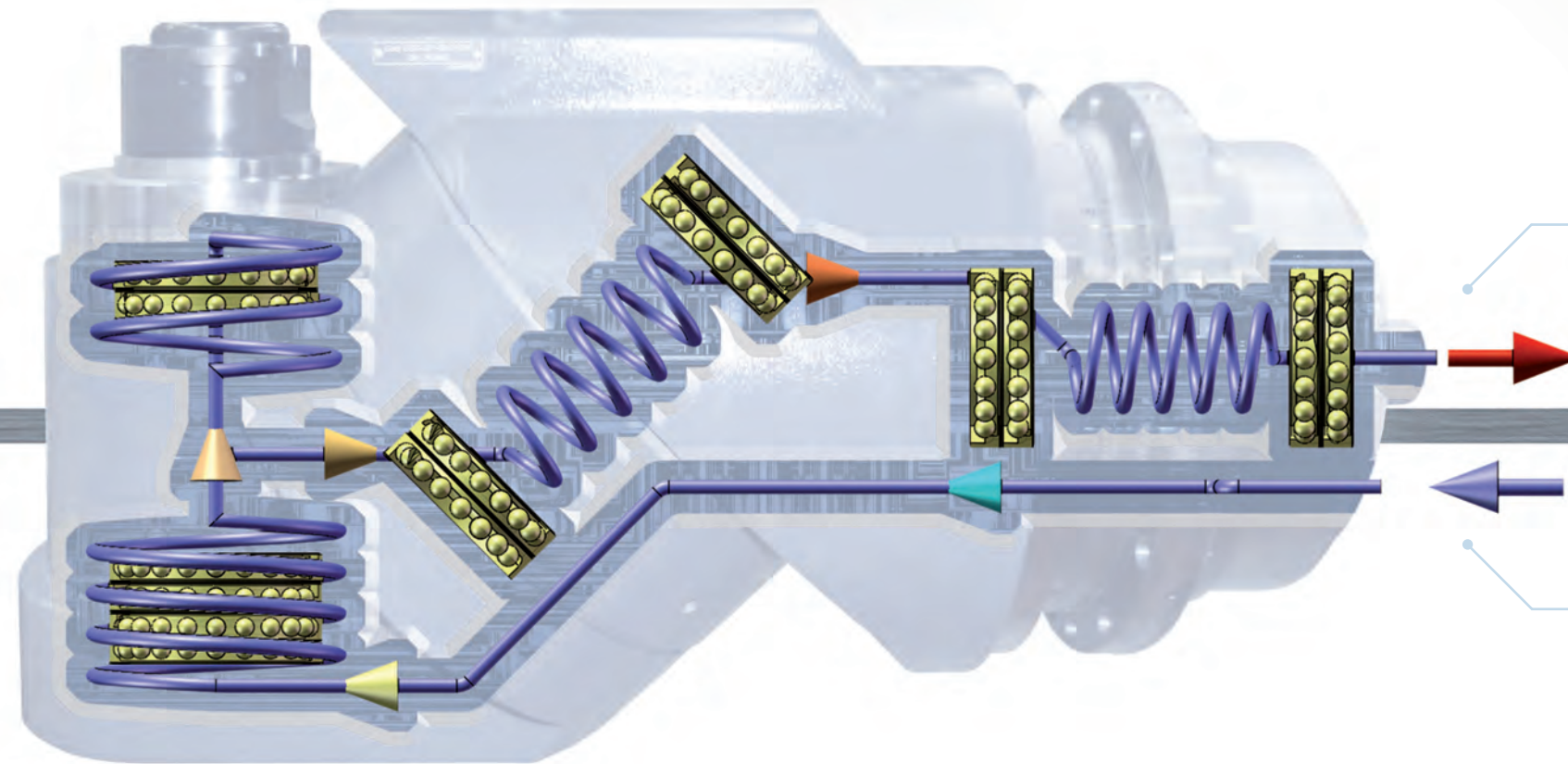

Milling Head

52 kW | 1.375 Nm | 6.000 rpm

Universal Auto-Indexing Differential Head

UAD 0.02° x 0.02°

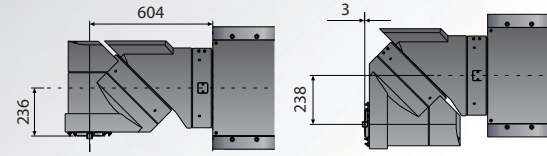

52 kW | 1.375 Nm | 4.000 rpm

Universal Auto-Indexing Differential Head

UGA 2.5° x 2.5°

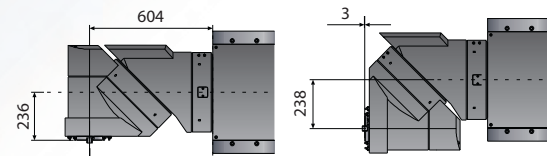

52 kW | 1.375 Nm | 6.000 rpm

Orthogonal Auto-Indexing Differential Head

OAD 0.02° x 0.02°

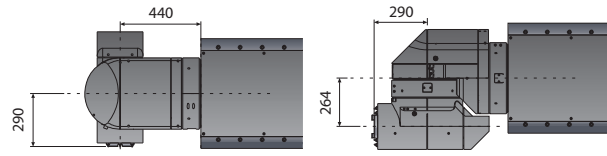

15 • 52 kW | 1.375 Nm | 3.000 • 4.000 rpm

Front Spindle

FC-20 | 30 | 60 | 80

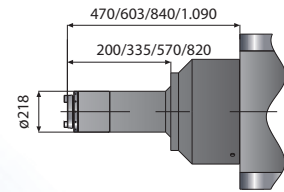

37 kW | 371 • 707 Nm | 4.000 rpm

2-Axis continuous Milling Head

CSE

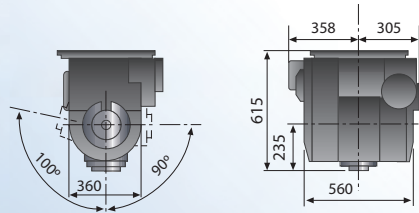

Milling Head

FD-20 | 30 | 60 | 80

Non-centered front spindle

15 • 52 kW | 1.375 Nm | 3.000 • 4.000 rpm

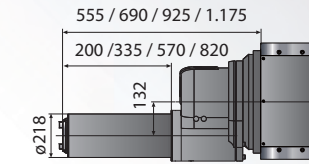
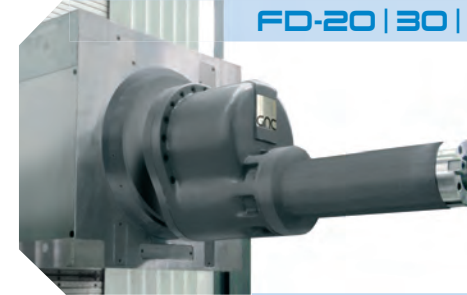

AL-600 2.5°

Reach-out Angle Milling Head

25 kW | 800 Nm | 1.500 rpm

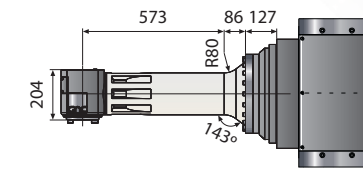

UT-500 | UT-630

D'Andrea Head

52 kW | 8.000 Nm | 315, 250 rpm

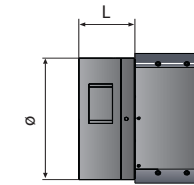

ESE Continuous

2-Axis continuous Milling Head

35 • 60 Kw | 12.000 • 24.000 rpm

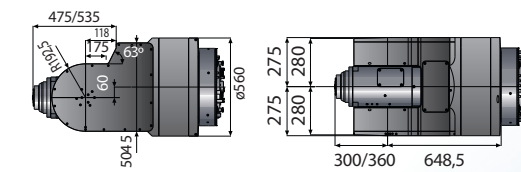
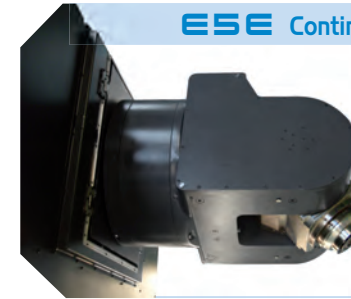

TU 2.5°

Turning and shaping Head

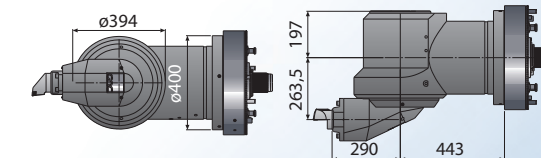

Milling Head Changer



MILLING HEAD	AUTOMATIC HEAD EXCHANGE	BUILT IN
UAD	•	•
UGA	•	•
OAD	•	•
FC-20 30 60 80	•	•
FD-20 30 60 80	•	•
AL-600	•	•
UT-500 UT-630	•	•
ESE Continuous	•	•
TU	•	•
CSE	•	•

Optional Equipment

Other heads

Automatic head-changer

Probes of measurement, tools and parts

Automatic charger for 30, 40, 60, 120 tools

Pick up station for 6, 8, 12 tools

Air/Coolant cleaning gun

Self cleaning filter

Rotary tables

Chip conveyors

Perimeter fence

Different enclosures according to user's needs (only in some models)

Coolant through spindle 17, 36, 70 bar

Zero Point Clamping System integrated in the machine

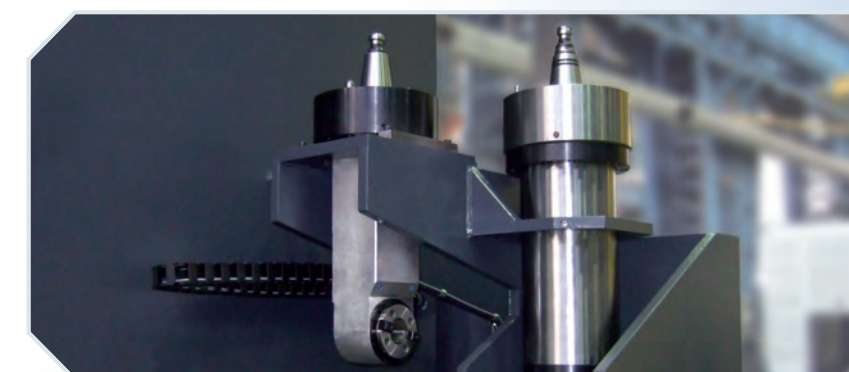
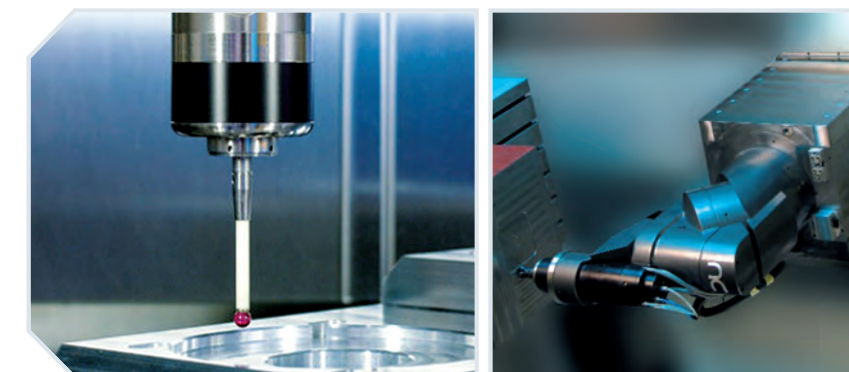
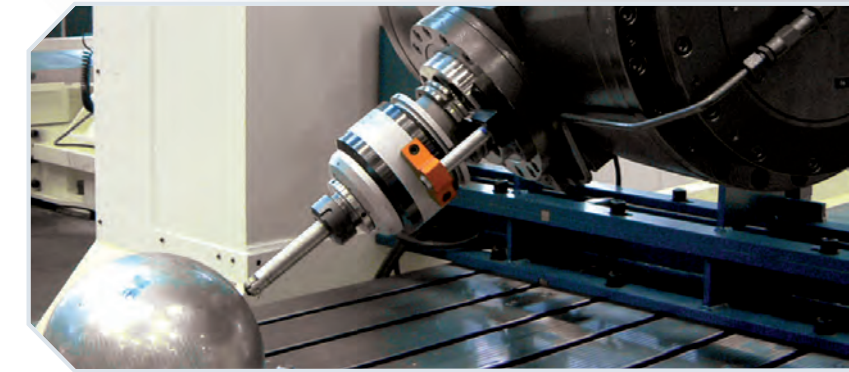

Applications

MACHINING OF INDUSTRIAL EQUIPMENT



MACHINING OF INDUSTRIAL EQUIPMENT



MACHINING WITH UAD HEAD EXTENSION



MACHINING OF INDUSTRIAL EQUIPMENT



MACHINING OF INDUSTRIAL EQUIPMENT



MACHINING OF INDUSTRIAL EQUIPMENT

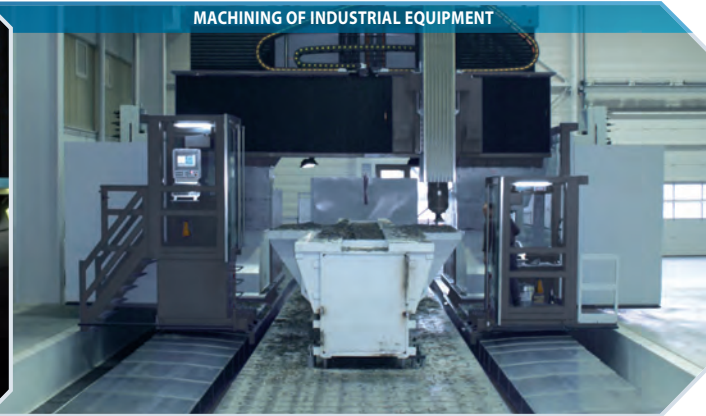

MACHINING OF AERONAUTICAL TOOLING



MACHINING OF AERONAUTICAL TOOLING



MACHINING OF AERONAUTICAL TOOLING



MACHINING OF AERONAUTICAL TOOLING



DOUBLE GANTRY INSTALLATION



MACHINING OF STAMPING DIES

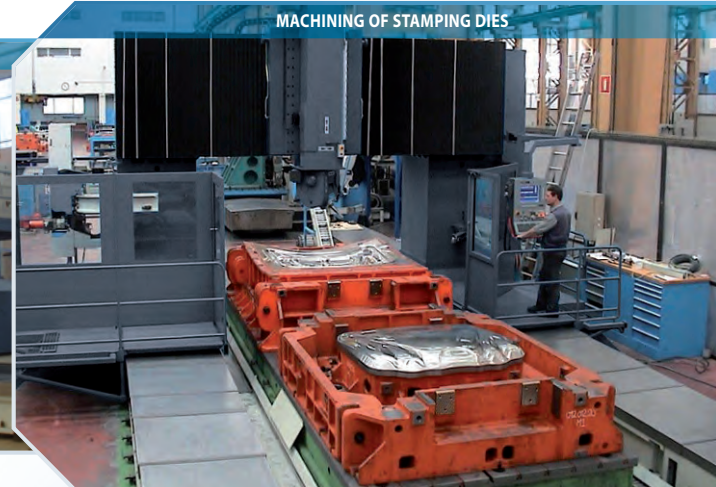



NICOLÁS CORREA S.A.

Founded in 1947 and dedicated to the design and fabrication of medium and large size milling machines, is the headquarters of the Group **NICOLÁS CORREA** also formed by 4 other industrial affiliates:

GNC HYPATIA

Design and fabrication of **CORREA** milling machines of small size, as well as accessories for the tool machine industry such as ATCs and milling heads.

GNC KUNMING

Fabrication and distribution of milling machines for the local chinese market.

GNC ELECTRÓNICA

Design and fabrication of electrical assemblies.

GNC CALDERERÍA

Welded structures, sheet parts, and machine guarding systems.

Some critical components are supplied inside the group to assure quality and fulfill the flexibility requirements of our customers.

In 2006 **NICOLÁS CORREA** and **INDUSTRIAS ANAYAK** merged, what gave us the chance to offer one of the widest milling machine ranges on the market including: bed type (Also T-Configuration), Travelling column (Also T-Configuration), Portal milling machines. The design and manufacture are entirely made in Europe.

It quotes in the Madrid Stock Exchange since 1989.

In order to guarantee service and personal assistance to our customers, we have a wide sales and service network all over the world, being present through subsidiaries or agents in most of the countries.

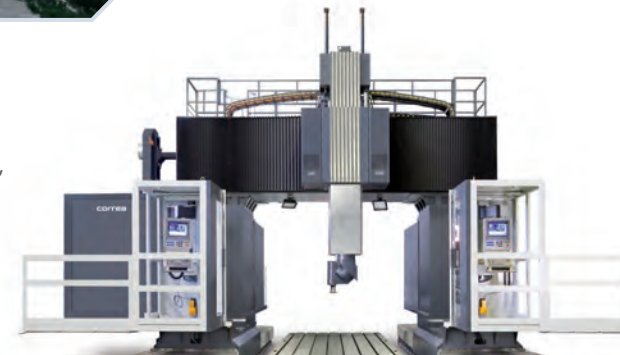

FOX-M



VERSA-M



VERSA-MW



FOX



VERSA



VERSA-W



NORMA-L



NORMA-FT



HVM



AXIA



MAGNA



XPERTA



PERFORMER-MG



NORMA



VH-PLUS-MG



HVM-LANZA



VH-PLUS LANZA

BORING MACHINES

GANTRY TYPE

BRIDGE TYPE

TRAVELLING COLUMN

BED TYPE